

Von Ruden Manufacturing, Inc.



2026-01

# FLUID POWER

## ROL-SEAL MOTORS

### RSA, RSB, MRS SERIES

 (763) 682-3122

 [VRM.Sales@vonruden.com](mailto:VRM.Sales@vonruden.com)

 [www.vonruden.com](http://www.vonruden.com)

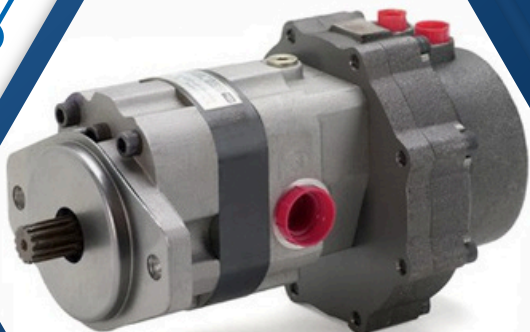
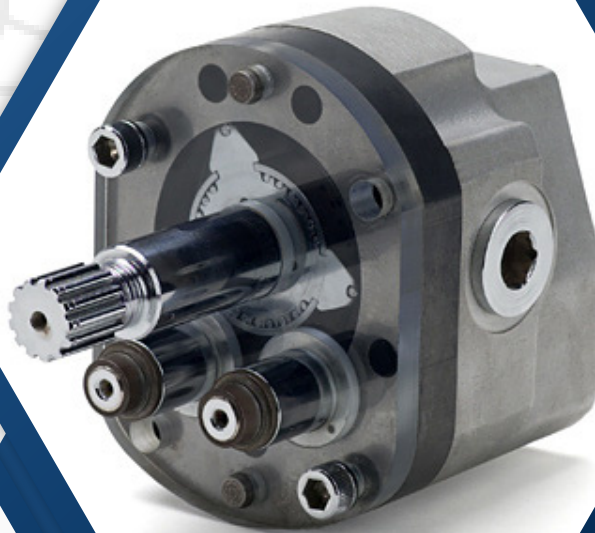
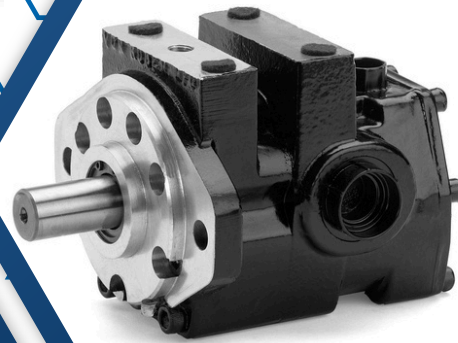

*\*All Von Ruden products are 100%  
manufactured and repaired in  
Buffalo, Minnesota\**

# TABLE OF CONTENTS



2026-01

## Hydraulic Motors & Accessories

03

### About Von Ruden

Learn about our 80 years as a family-owned, American manufacturer committed to precision, quality, and customer support.

04

### Fluid Power Products

Von Ruden Fluid Power offers high-performance hydraulic motors, brakes, and packages with a focus on torque, precision, and reliability.

05

### RSA, RSB, RSC Design

High starting and running torque, more useable speed, and long life. Positive contact provided by rolling seals creates relatively frictionless operation.

06

### RSA, RSB, RSC Data

Rol-Seal® general performance specifications, rotational moment of inertia, shaft radial, and thrust load capacity.

07 - 08

### RSA & RSB Data

Torque ranges shown for continuous and intermittent operation.

09

### RSA & RSB SAE 2-BOLT

RSA: SAE A 2-Bolt flange & side ports @ 180°.  
RSB: SAE B 2-Bolt flange & side ports @ 180°.

10

### RSA & RSB Manifold

RSA / RSB : Manifold mount & end/side ports.  
RSA: Foot mounting bracket.

11

### RSA / RSB Options

RSB: Front sealing cap option.  
RSA/RSB: Output shaft options & rear shaft extension options.

12

### RSC Data

Torque ranges shown for continuous and intermittent operation.

13 - 14

### RSC Options

RSC: SAE C 2-Bolt Flange & side ports @ 180°. | Front sealing cap option.  
Output shaft options, rear shaft extension options. | Available foot mounting bracket.

15

### Maintenance & Brakes

General Maintenance Issues on RSA, RSB, & RSC.  
All Rol-Seal® motors can be equipped with a rear-mounted, wet friction disc type brakes.

16 - 17

### Planetary Gearboxes

Torques to 25,000 lb-inches.  
Typical Performance Specifications.



# Von Ruden Manufacturing, Inc.



2026-01

**FLUID POWER**  
HYDRAULIC MOTORS

**MECHANICAL**  
BEVEL GEARBOXES

**TOOL PRODUCTS**  
DRIVEN TOOL HOLDERS

*A family-owned, 100% American-made company with 80 years of experience designing, manufacturing, repairing, and distributing high-performance components. Our products include live and static tooling for machine tools, as well as hydraulic motors, brakes, load adaptors, and bevel gearboxes for mobile and industrial markets.*

## QUALITY THAT DRIVES – SINCE 1946

Founded in southern Minnesota, Von Ruden began as a tractor saw manufacturer and quickly grew into a leader in motion and power transmission. Today, we manufacture premium hydraulic motors, gearboxes, brakes, tooling, and precision accessories, all designed to meet diverse performance, pricing, and delivery needs. For 80 years, our name has stood for quality, reliability, and innovation.



*Von Ruden was founded in 1946 in a small shed in Claremount, Minnesota.*



*Pictured Left to Right: Marketing Bennett Anderson, CEO Al Anderson, Administration Linda Anderson, and President Brandon Anderson.*

## RETURN TO FAMILY DRIVEN – SINCE 1989

In 1989, Von Ruden returned to family ownership when Al Anderson acquired the Power Components division from WSI. Relocating to Buffalo, MN, we focused on innovation, investing in cutting-edge technology. When market options didn't meet our standards, we engineered our own, launching into the driven tooling market in 1999. What began as an internal solution is now trusted by shops worldwide.

## ENGINEERING THE FUTURE

The future of Von Ruden is built on the same core values that shaped our legacy: quality, innovation, and customer-focused solutions.

From factory floors to field applications, you'll find Von Ruden products making a difference.



*\*All Von Ruden products are 100% manufactured and repaired in Buffalo, Minnesota\**

## FLUID POWER HYDRAULIC MOTORS

### ROL-SEAL® HYDRAULIC MOTORS

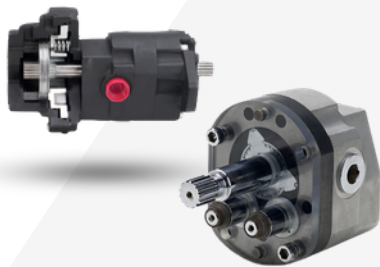

Unique rolling abutment design offers smooth low speed, high torque with a proven measurable difference. Compare with all others – gerotor, piston, and gear.

**Specifications:** (32 to 163cc)

- Seven displacements, 2 to 10 in<sup>3</sup> /rev.
- SAE A, B and C flanges and shafts.

**Benefits:**

- Higher starting torque (92%)
- 10 - 3500 RPM
- Up to 61 gpm, 3750 psi, 4777 lb-in
- Increased vehicle gradeability.
- Less torque “ripple” and “droop.”
- More useable speed and long service life
- Double-ended shaft capability.

### AXIAL VANE HYDRAULIC MOTORS

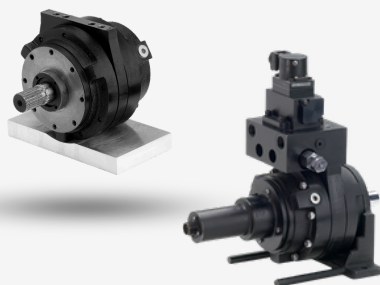

Ultimate hydraulic design for smooth, precise, repeatable positioning applications such as robotics.

**Specifications:** (16 to 115cc)

- Five displacements, 1 to 7 in<sup>3</sup> /rev.
- Options include tach generator, dual relief valves and rear shaft extension.

**Benefits:**

- High Starting Torque (97%)
- 10 - 3000 RPM
- Up to 46 gpm, 3000 psi, 2229 lb-in
- Accurate, repeatable positioning.
- Rigid for accuracy
- Smooth, balanced speed control
- Fewer wearing parts, exceptional life.

### OVERHUNG LOAD ADAPTORS



“Bearing Blocks” Increase hydraulic motor shaft load capacity and motor life.

**Specifications:**

- 5/8"- 1-3/4" Shaft Diameters
- Ball or tapered bearings
- Grease, oil, or feed lubrication
- 7 Model Series (MINI, SAE A - C)
- 2-Bolt / 4-Bolt mounted frames
- Keyed and splines shaft options

**Benefits:**

- Increase hydraulic motor life and radial/thrust loads.
- Easily remove or install hydraulic motors.
- Can be used to protect from motor shaft seal leak contamination.

### INTEGRAL ACCESSORIES



- Planetary Gearboxes
- Rear Mounted Integral Brake
- Radial Load Adaptor
- Manifold Mounting
- Rear Mounted Tach Packages
- Rear Mounted Shaft Extensions
- Duel Relief Valve Options

*\*All Von Ruden products are 100% manufactured and repaired in Buffalo, Minnesota\**

# RSA, RSB, RSC DESIGN



2026-01

## Rol-Seal Hydraulic Motors

### High Starting Torque

Efficiency typically falls within the 92-94% range, allowing designers to downsize motors and reduce overall hydraulic system costs. The higher starting torque also enhances vehicle gradeability and increases available drawbar pull.

### High Running Torque

Rolling-contact seal technology significantly reduces high-speed friction and viscous drag, while large flow passages minimize internal pressure drop. Breakaway pressure at no load is typically under 10 PSI.

### More Useable Speed

Delivers smooth operation below 10 RPM with minimal performance loss up to 3,500 RPM. Provides consistent performance across an exceptionally wide speed range, often eliminating the need for additional speed reduction.

### Long Life

Performance remains stable throughout the motor's service life. The internal rolling-seal elements are virtually frictionless, self-compensating for wear, and highly contamination-tolerant, ideal for demanding free-wheeling applications.

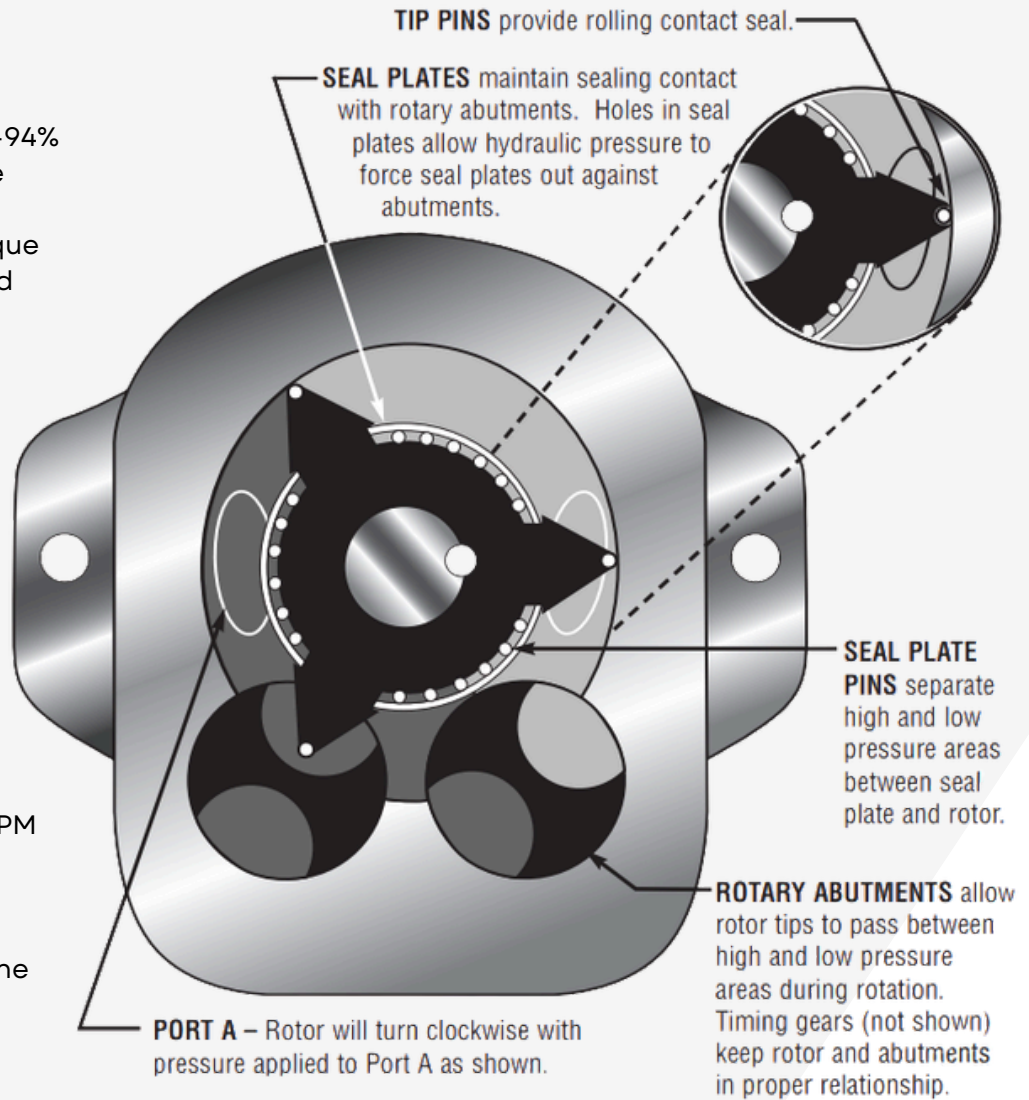

Low Pressure    Hi Pressure    Rotor & Abutment Valve Cross Section

#### The Rol-Seal's Rotary Abutment Advantage:

The positive contact provided by rolling seals between rotor and housing and between abutments and seal plates creates relatively frictionless operation

that makes these motors relatively insensitive to wear over their exceedingly long working life.

# RSA, RSB, RSC DATA

## Rol-Seal Hydraulic Motors



2026-01

### Rol-Seal General Performance Specifications

Displacement (in <sup>3</sup> /rev.)		RSA & RSB				RSC		
		2.0	3.0	4.0	5.0	6.0	8.0	10.0
Flow (gpm)	Continuous	18	20	18	17	39	42	39
	Intermittent	31	39	44	39	52	59	61
Max Speed <sup>1/4</sup> (rpm)	Continuous	2000	1500	1000	750	1500	1200	900
	Intermittent	3500	3000	2500	1800	2000	1700	1400
Δ Pressure <sup>2/3/4</sup> (psi)	Continuous	2500	2250	2000	2000	2000	2000	2000
	Intermittent	3000	3000	3000	3000	3000	3000	3000
	Peak	3750	3750	3500	3500	3500	3500	3500
Max Theoretical Torque (lb in)	Continuous	796	1075	1273	1592	1910	2547	3184
	Intermittent	955	1433	1910	2388	2866	3821	4777
Weight (lb)		13	14	15	16	36	39	42

Notes: 1. Intermittent conditions must be less than 10% of every minute.

3. Peak conditions are to be less than 1% of every minute.

2. Inlet and return pressures are not to exceed ratings listed above

4. Intermittent speed and peak pressure must not occur simultaneously.

### Rotational Moment of Inertia (WK<sup>2</sup>)

### Shaft Radial & Thrust Load Capacity

Model	Displacement (in <sup>3</sup> /rev)	lb-in <sup>2</sup>
RSA/RSB	2.0	1.23
	3.0	1.42
	4.0	1.61
	5.0	1.80
RSC	6.0	7.25
	8.0	8.15
	10.0	9.04

Model	Radial	Thrust
RSA/RSB	600 lbs <sup>2</sup>	600 lbs
RSC	1000 lbs <sup>3</sup>	1000 lbs

Notes: 1. Based on load located .5" from mounting flange.  
 2. Based on load located 1" from mounting flange.  
 3. Based on load located 1.5" from mounting flange

## Rol-Seal Hydraulic Motors

### RSA & RSB units: Torque Ranges Shown as “lb. in.@ RPM” for 2.0 in<sup>3</sup> /revolution displacement

Continuous Operation

Intermittent Operation - Less than Six Sec. / Min.

	250 PSI	500 PSI	1000 PSI	1500 PSI	2000 PSI	2500 PSI	3000 PSI	
FLOW RATE	<b>.25 GPM</b> <b>.5 GPM</b>	67 @ 9 67 @ 38	146 @ 23					
	<b>1 GPM</b> <b>2 GPM</b>	66 @ 95 66 @ 210	146 @ 81 144 @ 196	293 @ 57 290 @ 156	440 @ 28 438 @ 140	585 @ 99	735 @ 56 885 @ 6	
	<b>4 GPM</b> <b>8 GPM</b>	64 @ 440 59 @ 902	138 @ 431 133 @ 869	285 @ 389 280 @ 857	434 @ 376 429 @ 830	581 @ 330 576 @ 785	731 @ 289 726 @ 742	880 @ 237 876 @ 694
	<b>12 GPM</b> <b>16 GPM</b>	55 @ 1360 51 @ 1812	129 @ 1320 125 @ 1772	276 @ 1299 272 @ 1750	425 @ 1282 421 @ 1734	572 @ 1227 568 @ 1679	722 @ 1182 718 @ 1634	872 @ 1133 868 @ 1585
	<b>20 GPM</b> <b>25 GPM</b>	47 @ 2264 42 @ 2829	121 @ 2224 116 @ 2789	268 @ 2202 263 @ 2767	417 @ 2186 412 @ 2750	564 @ 2130 559 @ 2694	714 @ 2085 709 @ 2650	864 @ 2035 859 @ 2599
	<b>30 GPM</b> <b>35 GPM</b>	37 @ 3393	111 @ 3353	258 @ 3331	407 @ 3314	554 @ 3258	704 @ 3213	854 @ 3165
	<b>40 GPM</b>							

### RSA & RSB units: Torque Ranges Shown as “lb. in.@ RPM” for 3.0 in<sup>3</sup> /revolution displacement

Continuous Operation

Intermittent Operation - Less than Six Sec. / Min.

	250 PSI	500 PSI	1000 PSI	1500 PSI	2000 PSI	2500 PSI	3000 PSI	
FLOW RATE	<b>.25 GPM</b> <b>.5 GPM</b>	108 @ 4 108 @ 23	226 @ 10					
	<b>1 GPM</b> <b>2 GPM</b>	107 @ 61 104 @ 137	225 @ 48 222 @ 125	451 @ 29 448 @ 96	674 @ 67	898 @ 39	1120 @ 10	
	<b>4 GPM</b> <b>8 GPM</b>	99 @ 291 89 @ 598	217 @ 279 207 @ 587	443 @ 250 433 @ 558	669 @ 220 659 @ 528	893 @ 192 883 @ 500	1115 @ 163 1105 @ 470	1338 @ 134 1328 @ 442
	<b>12 GPM</b> <b>16 GPM</b>	79 @ 907 69 @ 1217	197 @ 895 187 @ 1203	423 @ 865 413 @ 1172	649 @ 835 639 @ 1140	873 @ 808 863 @ 1114	1095 @ 778 1085 @ 1085	1318 @ 750 1308 @ 1055
	<b>20 GPM</b> <b>25 GPM</b>	59 @ 1523 46 @ 1907	177 @ 1510 164 @ 1895	403 @ 1481 390 @ 1864	629 @ 1450 616 @ 1832	853 @ 1422 840 @ 1800	1075 @ 1394 1062 @ 1775	1298 @ 1361 1285 @ 1745
	<b>30 GPM</b> <b>35 GPM</b>	33 @ 2290 20 @ 2675	151 @ 2279 138 @ 2664	377 @ 2245 364 @ 2627	603 @ 2216 590 @ 2595	827 @ 2182 814 @ 2565	1049 @ 2155 1036 @ 2538	1272 @ 2128 1259 @ 2509
	<b>40 GPM</b>	7 @ 3061	125 @ 3048	351 @ 3010	577 @ 2978	801 @ 2946	1023 @ 2919	1246 @ 2890

## Rol-Seal Hydraulic Motors

### RSA & RSB units: Torque Ranges Shown as “lb. in.@ RPM” for 4.0 in<sup>3</sup> /revolution displacement

Continuous Operation

Intermittent Operation - Less than Six Sec. / Min.

	250 PSI	500 PSI	1000 PSI	1500 PSI	2000 PSI	2500 PSI	3000 PSI	
FLOW RATE	<b>.25 GPM</b> <b>.5 GPM</b>	148 @ 2 148 @ 17	313 @ 8					
	<b>1 GPM</b> <b>2 GPM</b>	146 @ 45 143 @ 102	311 @ 37 308 @ 94	612 @ 16 609 @ 80	910 @ 61	1211 @ 42	1512 @ 29	
	<b>4 GPM</b> <b>8 GPM</b>	136 @ 216 123 @ 442	301 @ 207 288 @ 433	602 @ 195 589 @ 418	904 @ 179 890 @ 399	1205 @ 157 1191 @ 380	1506 @ 139 1492 @ 360	1807 @ 105 1793 @ 325
	<b>12 GPM</b> <b>16 GPM</b>	110 @ 669 97 @ 891	275 @ 660 262 @ 881	576 @ 639 563 @ 860	877 @ 620 864 @ 840	1178 @ 601 1165 @ 821	1479 @ 581 1466 @ 802	1780 @ 546 1767 @ 766
	<b>20 GPM</b> <b>25 GPM</b>	84 @ 1113 68 @ 1392	249 @ 1104 233 @ 1382	550 @ 1081 534 @ 1357	851 @ 1060 835 @ 1337	1152 @ 2042 1136 @ 1318	1453 @ 1023 1437 @ 1299	1754 @ 987 1738 @ 1263
	<b>30 GPM</b> <b>35 GPM</b>	52 @ 1668 36 @ 1944	217 @ 1657 201 @ 1934	518 @ 1633 502 @ 1909	819 @ 1613 803 @ 1889	1120 @ 1594 1104 @ 1870	1421 @ 1575 1405 @ 1850	1722 @ 1539 1706 @ 1815
	<b>40 GPM</b>	20 @ 2220	185 @ 2209	486 @ 2184	787 @ 2165	1088 @ 2164	1389 @ 2126	1690 @ 2091

### RSA & RSB units: Torque Ranges Shown as “lb. in.@ RPM” for 5.0 in<sup>3</sup> /revolution displacement

Continuous Operation

Intermittent Operation - Less than Six Sec. / Min.

	250 PSI	500 PSI	1000 PSI	1500 PSI	2000 PSI	2500 PSI	3000 PSI	
FLOW RATE	<b>.25 GPM</b> <b>.5 GPM</b>	180 @ 11	368 @ 6					
	<b>1 GPM</b> <b>2 GPM</b>	180 @ 34 178 @ 79	370 @ 29 366 @ 74	755 @ 2 756 @ 49	1123 @ 30	1500 @ 9		
	<b>4 GPM</b> <b>8 GPM</b>	175 @ 169 159 @ 350	358 @ 165 342 @ 344	750 @ 144 734 @ 324	1115 @ 123 1099 @ 303	1496 @ 102 1480 @ 283	1860 @ 83 1844 @ 261	2220 @ 59 2204 @ 239
	<b>12 GPM</b> <b>16 GPM</b>	143 @ 530 127 @ 712	326 @ 522 310 @ 705	718 @ 507 702 @ 688	1083 @ 486 1067 @ 667	1464 @ 465 1448 @ 646	1832 @ 444 1816 @ 625	2188 @ 422 2172 @ 602
	<b>20 GPM</b> <b>25 GPM</b>	111 @ 895 91 @ 1120	295 @ 885 275 @ 1110	686 @ 867 666 @ 1094	1051 @ 848 1031 @ 1073	1432 @ 827 1412 @ 1053	1800 @ 806 1780 @ 1033	2156 @ 784 2135 @ 1009
	<b>30 GPM</b> <b>35 GPM</b>	70 @ 1345 51 @ 1570	255 @ 1334 235 @ 1558	646 @ 1321 626 @ 1546	1011 @ 1301 991 @ 1526	1392 @ 1279 1372 @ 1505	1760 @ 1258 1740 @ 1484	2116 @ 1235 2095 @ 1462
	<b>40 GPM</b>	30 @ 1795	215 @ 1785	606 @ 1773	971 @ 1751	1352 @ 1731	1719 @ 1710	2076 @ 1687

# RSA & RSB SAE 2-BOLT



2026-01

## Rol-Seal Hydraulic Motors

### RSA: WITH SAE A 2-BOLT FLANGE & SIDE PORTS @ 180°

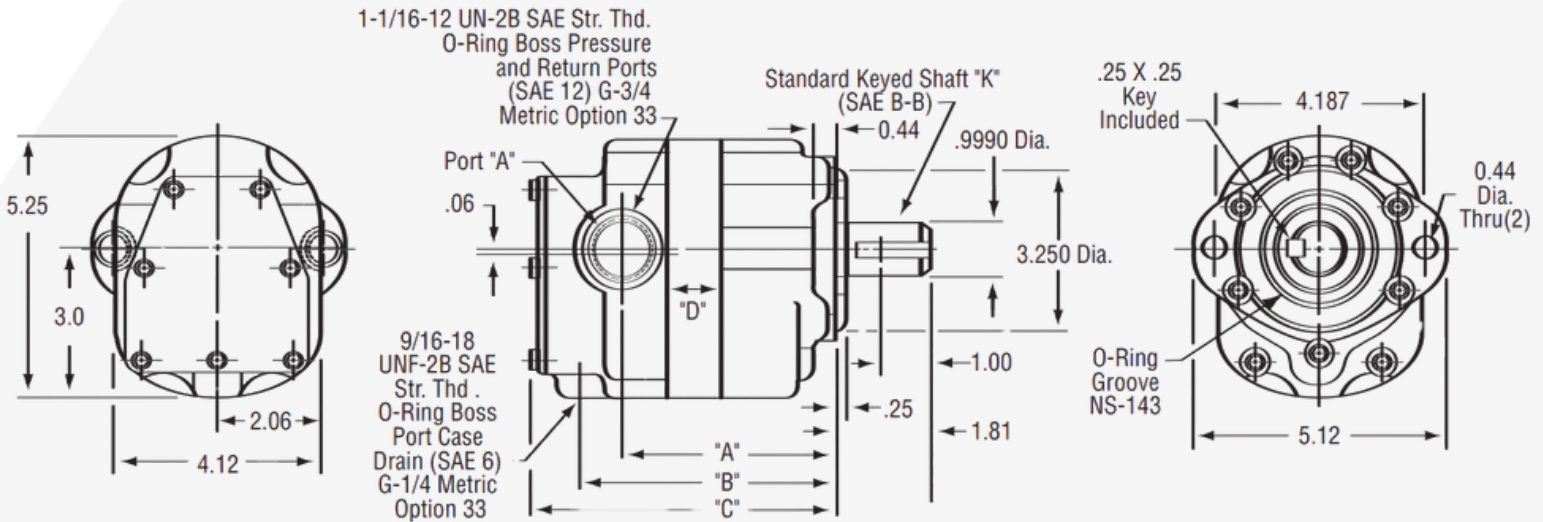

Displacement in <sup>3</sup> /Rev.	A	B	C	D
2.0	3.68	4.53	6.12	.65
3.0	4.02	4.87	6.46	.99
4.0	4.34	5.19	6.78	1.31
5.0	4.67	5.52	7.11	1.64

### RSB: WITH SAE B 2-BOLT FLANGE & SIDE PORTS @ 180°

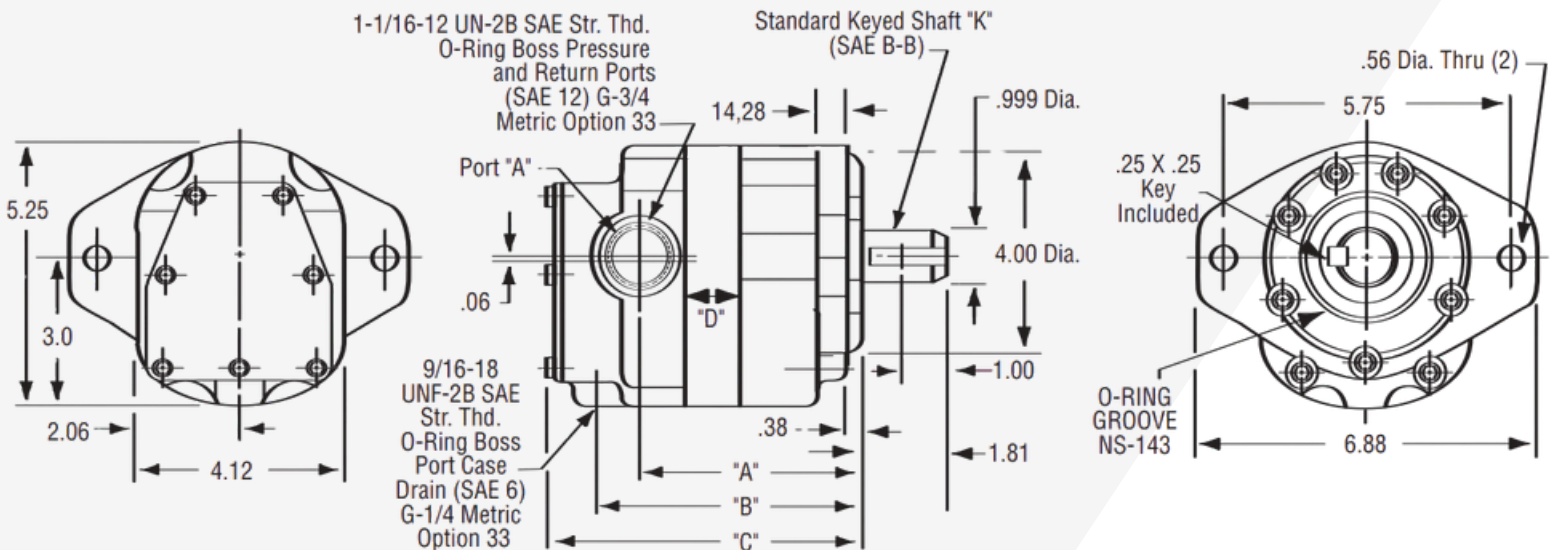

- Note: 1. All dimensions in inches and subject to change without notice. Always confirm with us that you are working with the most current data.  
2. Consult factory for specific machining tolerances.

# RSA & RSB MANIFOLD



## Rol-Seal Hydraulic Motors

2026-01

### RSA / RSB : MANIFOLD MOUNT & END / SIDE PORTS

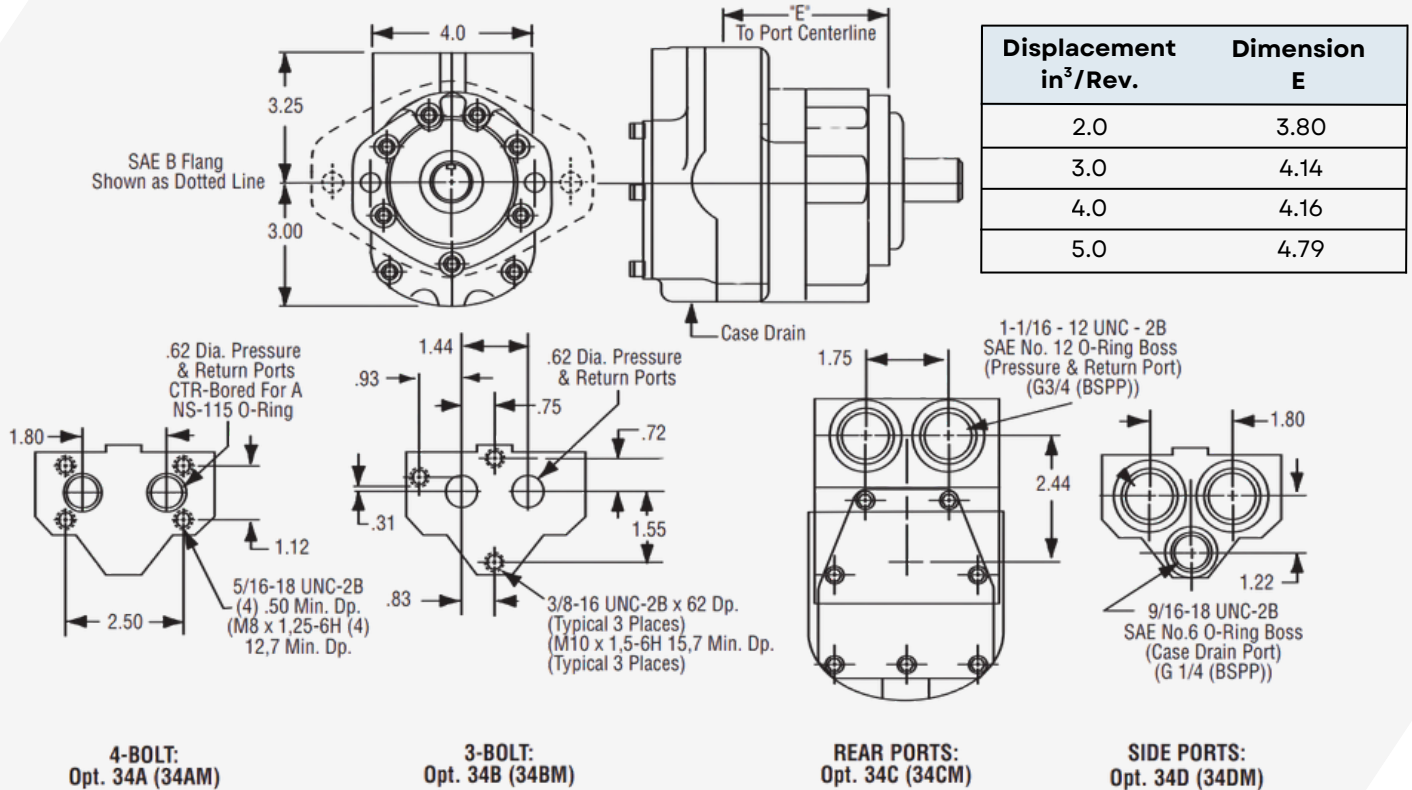

### RSA: FOOT MOUNTING BRACKET (Not Available for RSB)

Part # 63021 – RSA Only

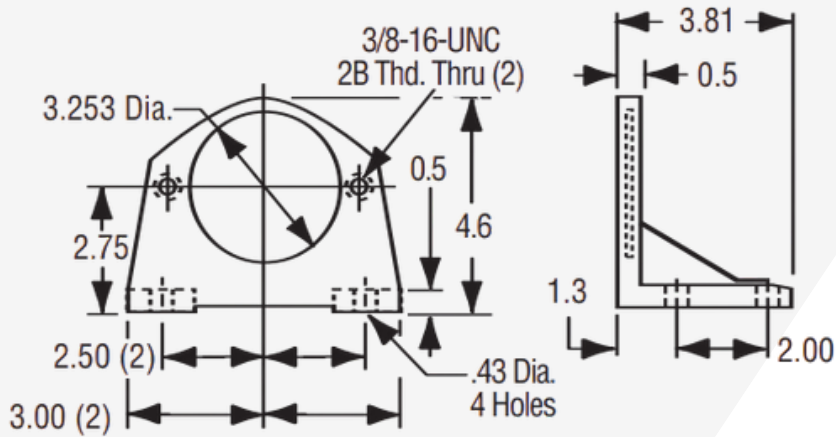

Note: 1. All dimensions in inches and subject to change without notice. Always confirm with us that you are working with the most current data.  
 2. Consult factory for specific machining tolerances.

# RSA / RSB OPTIONS



2026-01

## Rol-Seal Hydraulic Motors

### RSB FRONT SEALING CAP OPTION

RSB motors have mounting flange pilot diameters that are interrupted by bolt holes. If another device (for example, a gearbox) is going to be mounted, an O-ring gasket on the pilot diameter will not produce a seal between the two. If the gearbox or other such device does not have its own dynamic seal on its input shaft, then this motor option (#27) should be specified. Motors then will have turned-down pilot diameters and this front sealing cap (with O-rings between the sealing cap and motor).

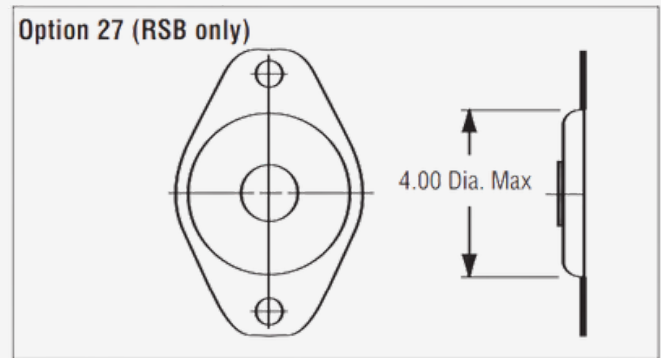

### RSA / RSB OUTPUT SHAFT OPTIONS

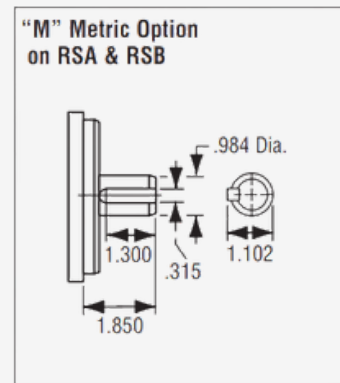
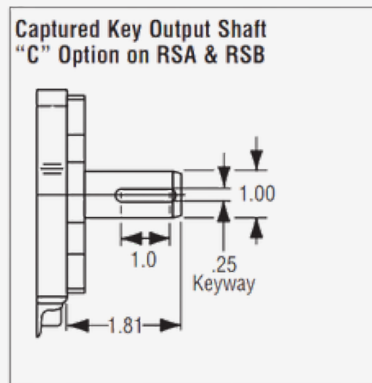
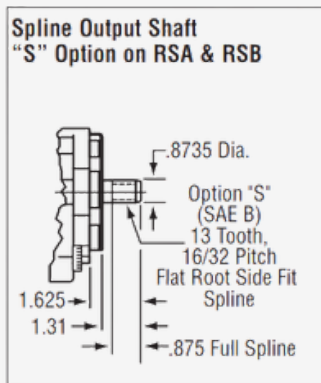

### RSA / RSB REAR SHAFT EXTENSION OPTIONS

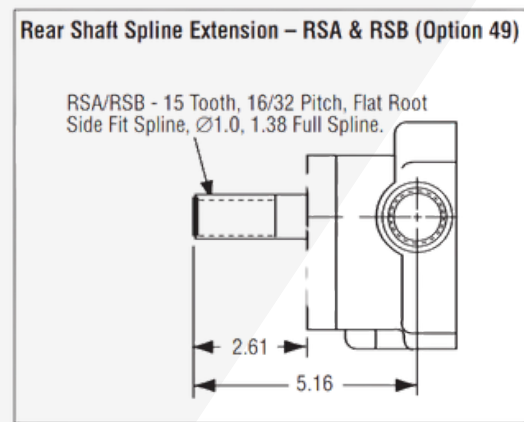
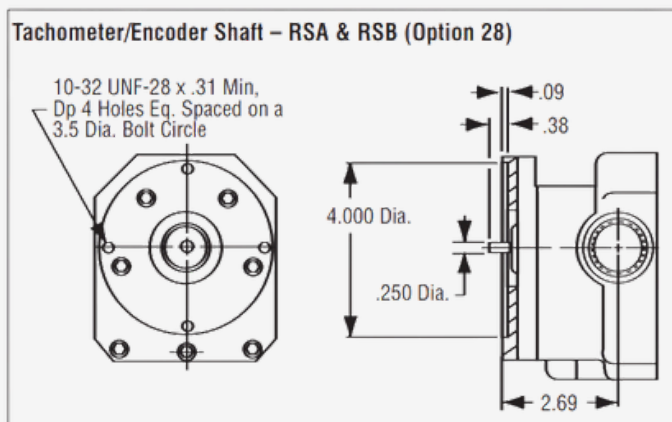

- Note: 1. All dimensions in inches and subject to change without notice. Always confirm with us that you are working with the most current data.  
2. Consult factory for specific machining tolerances.

## Rol-Seal Hydraulic Motors

### RSC units: Torque Ranges Shown as “lb. in.@ RPM” for 6.0 in<sup>3</sup> /revolution displacement

Continuous Operation

Intermittent Operation - Less than Six Sec. / Min.

		250 PSI	500 PSI	1000 PSI	1500 PSI	2000 PSI	2500 PSI	3000 PSI
FLOW RATE	<b>.25 GPM</b> <b>.5 GPM</b>	218 @ 27 219 @ 64	442 @ 17 442 @ 55	898 @ 23	1368 @ 10			
	<b>1 GPM</b> <b>2 GPM</b>	219 @ 138 209 @ 283	440 @ 128 431 @ 272	894 @ 100 884 @ 243	1365 @ 87 1355 @ 232	1825 @ 68 1815 @ 213	2257 @ 42 2248 @ 186	2709 @ 147
	<b>4 GPM</b> <b>8 GPM</b>	200 @ 434 190 @ 581	422 @ 424 412 @ 572	875 @ 394 865 @ 544	1346 @ 381 1336 @ 534	1806 @ 362 1796 @ 512	2238 @ 335 2227 @ 486	2699 @ 297 2690 @ 445
	<b>12 GPM</b> <b>16 GPM</b>	181 @ 732 169 @ 921	402 @ 722 390 @ 910	854 @ 694 842 @ 881	1326 @ 682 1313 @ 870	1785 @ 663 1772 @ 851	2218 @ 636 2207 @ 824	2681 @ 445 2670 @ 784
	<b>20 GPM</b> <b>25 GPM</b>	157 @ 1111 145 @ 1298	377 @ 1102 366 @ 1289	829 @ 1070 818 @ 1258	1302 @ 1059 1291 @ 1244	1761 @ 1038 1750 @ 1226	2194 @ 1012 2182 @ 1200	2657 @ 973 2645 @ 1162
	<b>30 GPM</b> <b>35 GPM</b>	131 @ 1481 107 @ 1857	354 @ 1472 331 @ 1847	805 @ 1444 782 @ 1818	1278 @ 1432 1255 @ 1805	1737 @ 1413 1713 @ 1788	2168 @ 1386 2146 @ 1760	2633 @ 1348 2608 @ 1723
	<b>40 GPM</b>	84 @ 2233	306 @ 2222	758 @ 2194	1230 @ 2182	1690 @ 2163	2122 @ 2135	2586 @ 2097

### RSC units: Torque Ranges Shown as “lb. in.@ RPM” for 8.0 in<sup>3</sup> /revolution displacement

Continuous Operation

Intermittent Operation - Less than Six Sec. / Min.

		250 PSI	500 PSI	1000 PSI	1500 PSI	2000 PSI	2500 PSI	3000 PSI
FLOW RATE	<b>.25 GPM</b> <b>.5 GPM</b>	298 @ 12 294 @ 41	609 @ 5 606 @ 34	1218 @ 17				
	<b>1 GPM</b> <b>2 GPM</b>	292 @ 99 279 @ 212	600 @ 91 587 @ 205	1217 @ 74 1204 @ 186	1840 @ 59 1827 @ 173	2450 @ 40 2444 @ 153	3030 @ 19 3025 @ 131	3560 @ 103
	<b>4 GPM</b> <b>8 GPM</b>	266 @ 310 253 @ 440	574 @ 302 562 @ 432	1191 @ 285 1179 @ 416	1814 @ 270 1802 @ 401	2431 @ 250 2418 @ 382	3012 @ 227 2999 @ 360	3547 @ 199 3534 @ 330
	<b>12 GPM</b> <b>16 GPM</b>	241 @ 554 225 @ 696	549 @ 546 533 @ 690	1166 @ 530 1150 @ 670	1789 @ 513 1772 @ 657	2405 @ 495 2389 @ 638	2986 @ 474 2970 @ 615	3520 @ 444 3504 @ 587
	<b>20 GPM</b> <b>25 GPM</b>	209 @ 838 193 @ 980	517 @ 831 500 @ 972	1133 @ 814 1117 @ 956	1756 @ 798 1740 @ 942	2373 @ 779 2356 @ 922	2954 @ 756 2938 @ 900	3488 @ 728 3472 @ 872
	<b>30 GPM</b> <b>35 GPM</b>	177 @ 1122 145 @ 1406	485 @ 1115 453 @ 1400	1102 @ 1097 1069 @ 1380	1725 @ 1083 1692 @ 1367	2340 @ 1064 2308 @ 1348	2922 @ 1040 2890 @ 1326	3456 @ 1012 3424 @ 1295
	<b>40 GPM</b>	113 @ 1691	421 @ 1682	1037 @ 1665	1660 @ 1650	2276 @ 1632	2858 @ 1610	3392 @ 1556

Notes: 1. Performance data shown above is typical at 156 SSU fluid viscosity. Actual data may vary slightly from unit to unit in production.  
2. All numbers subject to change without notice. Always confirm with us that you are working with the most current data.

## Rol-Seal Hydraulic Motors

**RSC units: Torque Ranges Shown as “lb. in. @ RPM” for 10.0 in<sup>3</sup> /revolution displacement**

Continuous Operation

Intermittent Operation – Less than Six Sec. / Min.

	250 PSI	500 PSI	1000 PSI	1500 PSI	2000 PSI	2500 PSI	3000 PSI	
FLOW RATE	<b>.25 GPM</b>	370 @ 16	760 @ 7					
	<b>.5 GPM</b>	372 @ 38	768 @ 31	1545 @ 22				
	<b>1 GPM</b>	370 @ 84	765 @ 78	1540 @ 69	2340 @ 42	3098 @ 28	3824 @ 16	
	<b>2 GPM</b>	354 @ 169	749 @ 163	1525 @ 148	2320 @ 135	3100 @ 122	3820 @ 111	4535 @ 81
	<b>4 GPM</b>	338 @ 258	733 @ 252	1507 @ 238	2308 @ 226	3084 @ 212	3804 @ 200	4519 @ 182
	<b>8 GPM</b>	323 @ 353	717 @ 344	1492 @ 332	2290 @ 318	3068 @ 305	3785 @ 292	4500 @ 274
	<b>12 GPM</b>	306 @ 443	700 @ 436	1475 @ 424	2275 @ 412	3050 @ 398	3770 @ 386	4483 @ 367
	<b>16 GPM</b>	285 @ 556	682 @ 550	1453 @ 536	2254 @ 522	3032 @ 510	3752 @ 498	4465 @ 480
<b>20 GPM</b>	266 @ 671	662 @ 666	1435 @ 652	2235 @ 639	3010 @ 625	3730 @ 612	4446 @ 594	
<b>25 GPM</b>	245 @ 784	640 @ 780	1415 @ 765	2216 @ 752	2991 @ 739	3711 @ 727	4427 @ 707	
<b>30 GPM</b>	226 @ 902	619 @ 894	1396 @ 882	2192 @ 868	2970 @ 855	3692 @ 844	4405 @ 825	
<b>35 GPM</b>	185 @ 1125	581 @ 1119	1356 @ 1105	2152 @ 1093	2931 @ 1080	3650 @ 1068	4365 @ 1049	
<b>40 GPM</b>	146 @ 1350	540 @ 1346	1312 @ 1331	2112 @ 1322	2890 @ 1308	3608 @ 1296	4323 @ 1276	

Notes: Performance data shown above is typical at 156 SSU fluid viscosity. Actual data may vary slightly from unit to unit in production.

### RSC WITH SAE C 2-BOLT FLANGE & SIDE PORTS @ 180°

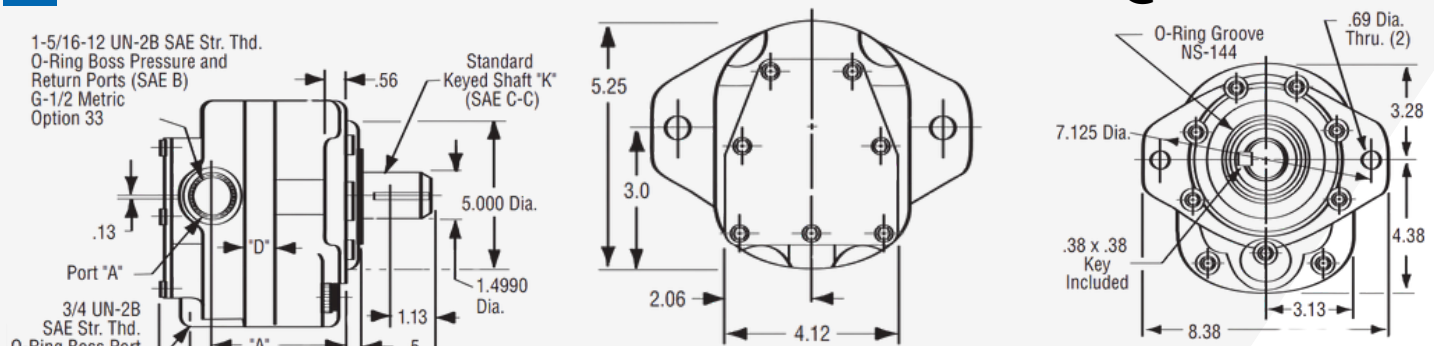

Displacement in <sup>3</sup> /Rev.	A	B	C	D
6.0	4.18	5.15	6.46	.89
8.0	4.46	5.43	6.75	1.18
10.0	4.75	5.75	7.06	1.54

Notes: 1. All dimensions in mm and subject to change without notice. Always confirm with us that you are working with the most current data.  
2. Consult factory for specific machining tolerances.

### RSC Front Sealing Cap Option

RSC motors have mounting flange pilot diameters that are interrupted by bolt holes. If another device (ex. gearbox) is mounted, an O-ring gasket on the pilot diameter will not produce a seal between the two. If the gearbox or other device does not have its own dynamic seal on its input shaft, then motor option (#27) should be specified. Your motors then will have turned-down pilot diameters and this front sealing cap (with Orings between the sealing cap and motor).

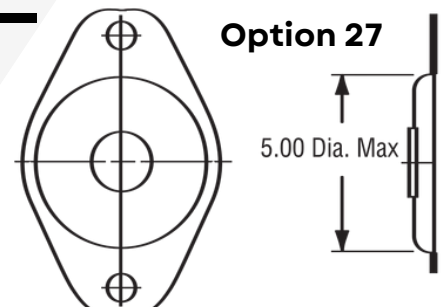

### RSC OUTPUT SHAFT OPTIONS

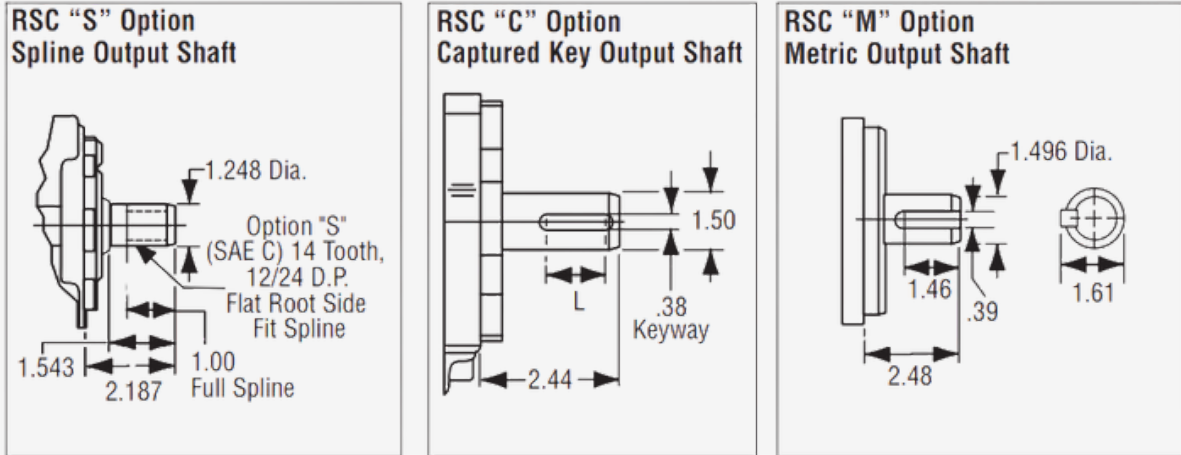

### RSC AVAILABLE FOOT MOUNTING BRACKET

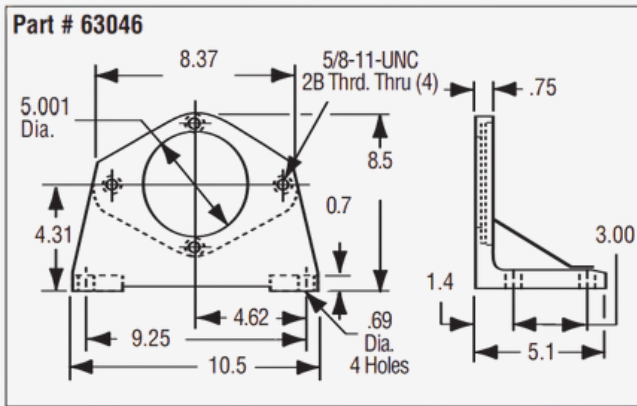

### RSC REAR SHAFT EXTENSION OPTIONS

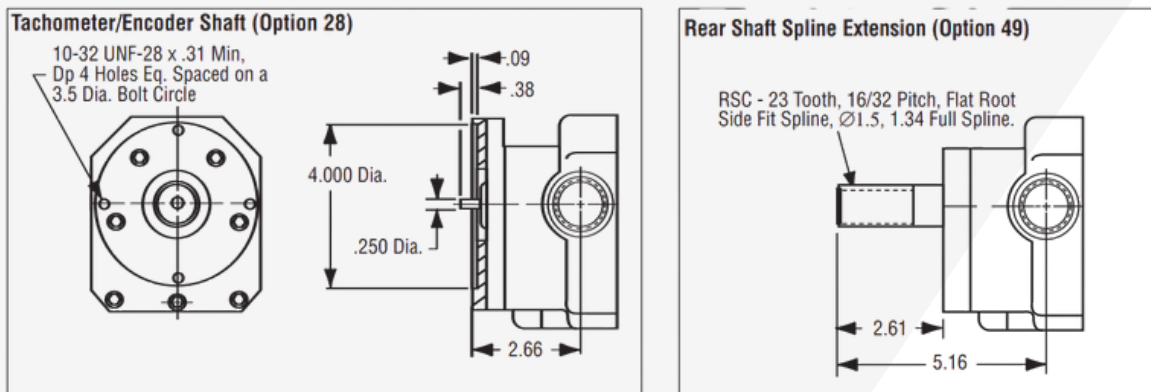

Note: 1. All dimensions in inches and subject to change without notice. Always confirm with us that you are working with the most current data.  
 2. Consult factory for specific machining tolerances.

## Rol-Seal Hydraulic Motors

### General Maintenance Issues on RSA, RSB, & RSC

#### Fluids:

We recommend a premium quality, anti-wear type mineral based hydraulic fluid with a minimum oil viscosity of 70 ssu. Maximum operating temperature is 180° F.

#### Filtration:

Fluid cleanliness level of ISO 17/14 should be maintained at all times. Nominal filtration must be 25 micron or better.

#### Case Drain:

These motors are provided with a case drain port that must be connected to the reservoir with no more than 250 PSI surge pressure. Internal cross port check valves (option-24) can be provided when motors are not subject to instantaneous shock pressures (such as with dynamic braking).

## POWER TRAIN ACCESSORIES - RSA, RSB, RSC

### MOTOR BRAKES

All Rol-Seal® motors can be equipped with a rear-mounted, normally on, wet friction disc type brakes. They will prevent creep under high static loads which might result from system leakage. They also should be used where positive locking of the motor shaft is required.

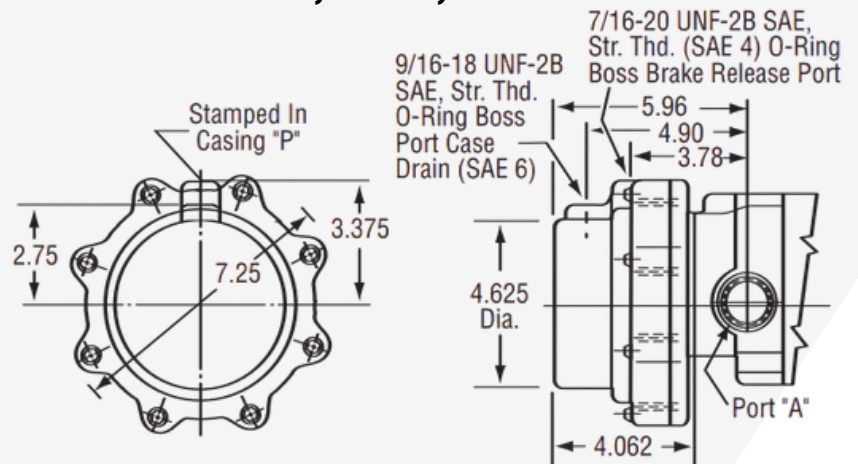

Maximum Release Pressure: 3000 PSI

Oil Volume: .6 in.3 for full release

Minimum Holding Capacity: See chart.

Note that chart data assumes the use of mineral-based oil with no back pressure in release line.

In applications where excessive holding torque is a concern, please consult factory.

Brake Model	Min. Holding Capacity at 250 PSI Release Pressure	Brake Model	Min. Holding Capacity at 125 PSI Release Pressure
222	940 lb/in	232	470 lb/in
223	1410 lb/in	233	705 lb/in
224	1885 lb/in	234	940 lb/in
226	2820 lb/in	236	1410 lb/in
228	3760 lb/in	238	1885 lb/in
220	5170 lb/in	230	1585 lb/in

Notes: 1. Dimensions shown are in inches. Always confirm with us that you are working with the most current data.  
2. All numbers are subject to change without notice.

# PLANETARY GEARBOXES



2026-01

## Fluid Power

### MODEL 200B



- Torques to 25,000 lb-inches.
- Five gear ratios. Up to 10:1.
- Maximum output speed 350 R.P.M.
- Bi-directional rotation.
- 95-98% mechanical efficiency.
- Sealed output bearing requires no grease.
- Choice of output shafts

Gear Ratio		Input Torque (LB-IN)		Output Torque (LB-IN)		Maximum Continuous Horsepower (Thermal)
Nominal	Actual	Continuous	Intermittent*	Continuous	Intermittent*	
10:1	9.94:1	1510	2515	15000	25000	17
8:1	8.06:1	1860	3100	15000	25000	17
7:1	7.07:1	2040	3400	14425	24040	17
6:1	5.85:1	2225	3710	13020	21700	17
5:1	5.2:1	2350	3915	12220	20360	17

\*Intermittent conditions are less than 10% of every minute. Intermittent torque and intermittent speed must not occur simultaneously.

### MAX OUTPUT SHAFT LOAD CAPACITIES

Load (LBS)	R.P.M.				
	25	50	100	200	300
Radial	6490	5275	4285	3480	3080
Thrust	6660	5415	4400	3570	3160

Radial capacities shown are with load located 1.5 inches from mounting face of gear box. Maximum radial and thrust loads should not occur simultaneously.

### MAX OUTPUT SHAFT LOAD CAPACITIES

- Ring gear- Case hardened alloy steel
- All other gears and pinion shafts - Case hardened alloy steel
- Housing - Ductile iron
- Output shaft - High tensile ductile iron
- Output bearings-Sealed double row ball bearing

## Rol-Seal Hydraulic Motors

### ROL-SEAL MOTORS/BRAKES/SAE GEARBOXES

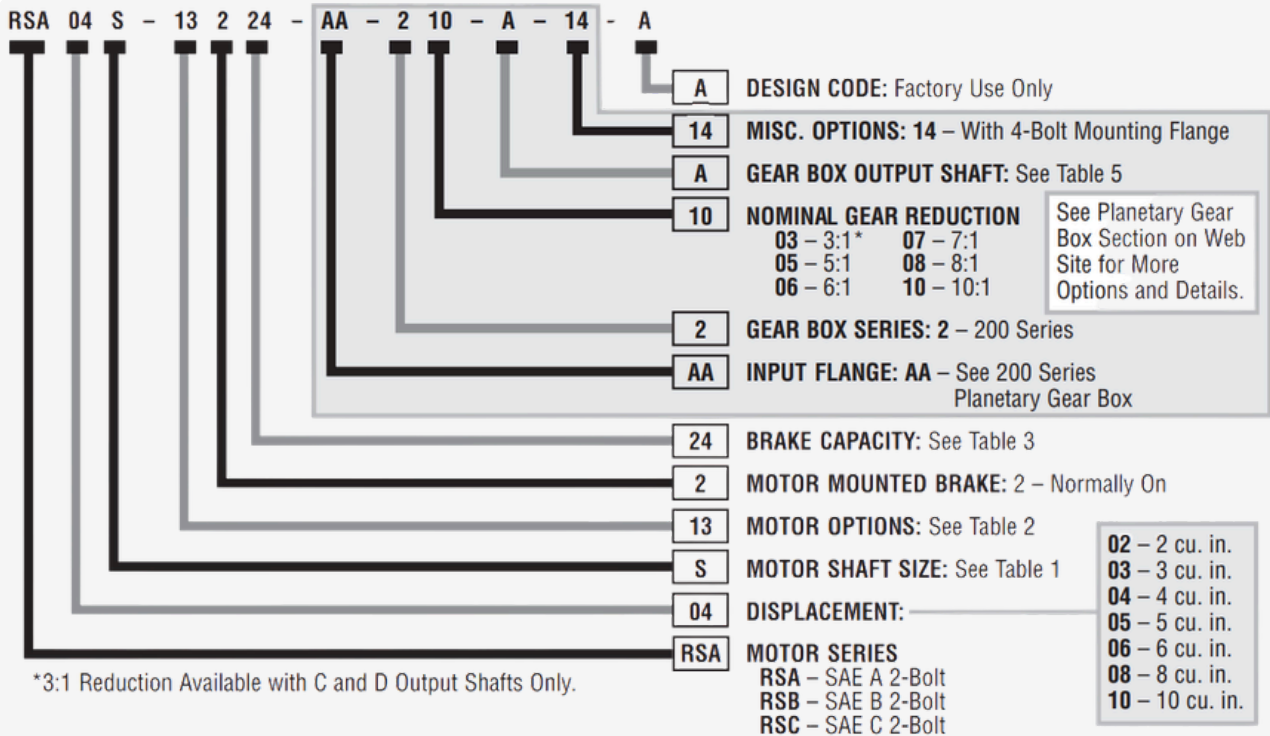

<p><b>Table 1: MOTOR SHAFT SIZES</b></p> <p><b>RSA</b>                  C – ø1" Keyed (.25" captured key)                  K – ø1" Keyed (.25" key)                  M – 25mm Keyed (8x7x32)                  S – 13 Tooth 16/32 Pitch Spline ø .875"</p> <p><b>RSB</b>                  C – ø1" Keyed (.25" captured key)                  K – ø1" Keyed (.25" key)                  M – 25mm Keyed (8x7x32)                  S – 13 Tooth 16/32 Pitch Spline ø .875"</p> <p><b>RSC</b>                  C – ø1" Keyed (.38" captured key)                  K – ø 1.5" Keyed (.375" key)                  M – 38mm Keyed (10x8x36)                  S – 14 Tooth 12/24 Pitch Spline ø 1.25"</p> <p>KEYS INCLUDED                  *S Shafts are for 200 Series Box</p>	<p><b>Table 2: MOTOR OPTIONS</b></p> <p>13 – Viton Seals                  24 – Internal Drain                  27 – Front Sealing Cap (RSB &amp; RSC Only)                  28 – Tach. Adapter                  33 – Side Ports 180° Metric (BSP)                  RSA/B Work Ports G 3/4                  Drain Port G 1/4                  RSC Work Ports G 1                  Drain Port G 1/2</p> <p>34A – Manifold, .62" Ports, 4 Bolt                  34B – Manifold, .62" Ports, 3 Bolt                  34C – Rear Ports, SAE 12                  34D – Side Ports, SAE 12</p> <p>34AM – Manifold, Metric 15,7 Ports, 4 Bolt                  34BM – Manifold, Metric 15,7 Ports, 3 Bolt                  34CM – Metric Rear Ports G 3/4                  34DM – Metric Side Ports Ports G 3/4</p> <p>49 – Splined Rear Shaft Extension                  52 – For 95/5 Fluids</p>	<p><b>Table 3: BRAKE CAPACITY</b></p> <table border="1"> <thead> <tr> <th>250 PSI Release</th> <th>125 PSI Release</th> </tr> </thead> <tbody> <tr> <td>22 940 lb. in.</td> <td>32 470 lb. in.</td> </tr> <tr> <td>23 1410 lb. in.</td> <td>33 705 lb. in.</td> </tr> <tr> <td>24 1885 lb. in.</td> <td>34 940 lb. in.</td> </tr> <tr> <td>26 2820 lb. in.</td> <td>36 1410 lb. in.</td> </tr> <tr> <td>28 3760 lb. in.</td> <td>38 1885 lb. in.</td> </tr> <tr> <td>20 1570 lb. in.</td> <td>30 2585 lb. in.</td> </tr> </tbody> </table> <p><b>Table 5: GEAR BOX OUTPUT SHAFTS</b></p> <p>A – ø 2.125" Straight Keyed (.5" key)                  B – 16 Tooth 8/16 Pitch Spline ø 2.125"                  C – ø 1.875" Straight Keyed (.5" key)                  D – 13 Tooth 8/16 Pitch Spline ø 1.75"</p>	250 PSI Release	125 PSI Release	22 940 lb. in.	32 470 lb. in.	23 1410 lb. in.	33 705 lb. in.	24 1885 lb. in.	34 940 lb. in.	26 2820 lb. in.	36 1410 lb. in.	28 3760 lb. in.	38 1885 lb. in.	20 1570 lb. in.	30 2585 lb. in.
250 PSI Release	125 PSI Release															
22 940 lb. in.	32 470 lb. in.															
23 1410 lb. in.	33 705 lb. in.															
24 1885 lb. in.	34 940 lb. in.															
26 2820 lb. in.	36 1410 lb. in.															
28 3760 lb. in.	38 1885 lb. in.															
20 1570 lb. in.	30 2585 lb. in.															

© Rol-Seal is a Registered Trademark of Von Ruden Manufacturing, Inc.

Note: 1. All dimensions in inches and subject to change without notice. Always confirm with us that you are working with the most current data.

## FLUID POWER HYDRAULIC MOTORS

### ROL-SEAL®



- Displacements: 2-10 in<sup>3</sup>
- Motor Series: SAE "A" "B" "C"
- Rotary Abutment Advantage
- Integral Brake/Planetary Gearbox

### AXIAL VANE



- Displacements: 1-7 in<sup>3</sup>
- 97% Efficiency
- Mechanically Stiff Rotor/Shaft
- Integral Brake/Planetary Gearbox

### OVERHUNG LOAD ADAPTOR



- 7 Model Series
- SAE "A" "B" "C"
- 2 or 4 Bolt Mounting
- Standard/Heavy Duty Bearings

## MECHANICAL RIGHT ANGLE BEVEL GEARBOXES

### MODELS



- 9 Model Series
- 2-4 Shaft Configurations
- SAE Motor Mount Flange

### OPTIONS



- Up to 200 Horsepower
- Ratio Options: 1:1-3/3-1:1
- Spiral or Straight Cut Gears

### DESIGN



- All Components Machined
- Press Fit Internal Components
- Shimmed for Backlash

## TOOL PRODUCTS DRIVEN TOOL HOLDERS

### BRANDS

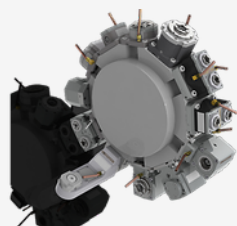

- DMG MORI
- DN SOLUTIONS
- HAAS
- MAZAK
- OKUMA

### OPTIONS



- BMT & VDI Mounting
- Face/OD Machining
- Ratio Options: 1:1 / 1:2 / 2:1
- 500/1500 PSI Through Coolant
- Multiple Spindle Options

### DESIGN



- Machine Specific Designs
- ER Recessed Spindles
- Industry leading Bearing Capacity
- ABEC 7/9 Spindle Bearings
- ICL Mechanical Sealing Systems

\*All Von Ruden products are 100% manufactured and repaired in Buffalo, Minnesota\*