

## VON RUDEN WARRANTY CLAIM FORM

DISTRIBUTOR: \_\_\_\_\_  
 DEALER: \_\_\_\_\_  
 CUSTOMER: \_\_\_\_\_  
 CUST. TYPE: COMMERCIAL / OWNER-OPERATOR / RESIDENTIAL / RENTAL  
 CLAIM DATE: \_\_\_\_\_  
 DECK S/N: \_\_\_\_\_

MODEL NUMBER: \_\_\_\_\_  
 SERIAL NUMBER: \_\_\_\_\_  
 IN SERVICE DATE: \_\_\_\_\_  
 PREVIOUS REPAIRS?: YES / NO  
 FAILURE DATE: \_\_\_\_\_  
 DECK HOURS: \_\_\_\_\_

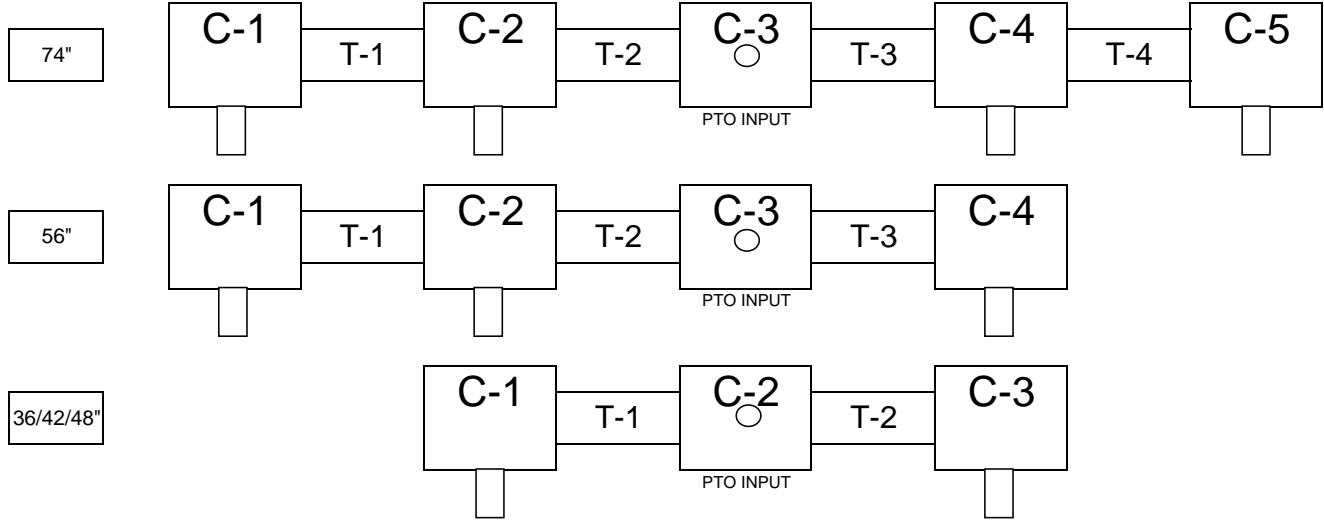

**\*\*VIEW LOOKING AT INPUT SIDE OF BLADE DRIVE ASSEMBLY\*\* MARK LOCATION OF FAILURE(S) WITH AN "X"**

PART	FAILURE	CAUSE	CASE	TUBE	NOTE(S)
O-RING	LEAK	GEARBOX FLEX			
		INTERNAL FAILURE			
		CRACKED CASE/FLANGE			
		BAD O-RING			
SEAL	LEAK	INTERNAL FAILURE			
		SHAFT ENDPLAY			
		OVERFILL OF OIL			
		IMPACT(S)			
SHAFT	ENDPLAY	BAD SEAL			
		RETAINING RING LOOSE			
		LOCKNUT LOOSE			
	THREAD DAMAGE <sup>(1)</sup>	BEARING FAILURE			
		GEAR FAILURE			
FLATS DEFORMED <sup>(2)</sup>	CROSS THREAD NUT				
SHEARED OFF <sup>(3)</sup>	WORN/LOOSE TRASH GUARD				
	WORN/LOOSE TRASH GUARD				
	DEFORMED TRASH GUARD				
GEAR	SINGLE TOOTH BROKE <sup>(4)</sup>	IMPACT(S)			
		INTERNAL FAILURE			
	MULTIPLE TEETH BROKEN <sup>(5)</sup>	IMPACT(S)			
		INTERNAL FAILURE			
	ALL OR MULTIPLE TEETH WORE DOWN OR FOLDED OVER <sup>(6)</sup>	GEARBOX FLEX			
		BEARING FAILURE			
BEARING	ROLLER / BALL DISTORTION	INTERNAL FAILURE			
		GEARBOX FLEX			
		BEARING FAILURE			
		INTERNAL FAILURE			
	SKID / SPIN	LACK OF LUBRICATION			
		SHAFT ENDPLAY			
		IMPACT(S)			
		ASSEMBLY DISTORTION			
		GEAR FAILURE			
		LACK OF LUBRICATION			
NOTE(S): ATTACH SEPARATE PAGE		ASSEMBLY DISTORTION			
		INTERNAL FAILURE			
		SHAFT ENDPLAY			
		BAD BEARING			
		IMPROPER FIT			

**Fax completed form to: (763) 682-3954**

VON RUDEN WARRANTY CLAIM REPORT

EXAMPLE PICTURES OF FAILURE TYPES

1) THREAD DAMAGE



2) FLAT AND HOLE DAMAGE



3) BROKEN SHAFT



4) BROKEN GEAR (SINGLE TOOTH)



5) BROKEN GEAR (MULTIPLE TEETH)



6) BROKEN GEARS (WORN/FOLDED TEETH)

