

Von Ruden Manufacturing, Inc.  
 1008 First Street N.E.  
 Buffalo, MN 55313 U.S.A.  
 Phone: (763) 682-3122  
 Fax: (763) 682-3954  
 Internet: www.vonruden.com

## VON RUDEN OVERHUNG LOAD ADAPTORS (BEARING BLOCKS)



Specials Available  
 Upon Request



Bodies are made of quality 35,000 tensile strength cast iron material for dependability.



All models are drilled with correct holes for mounting (SAE or Industry Standard) using 2 or 4 bolt flanges. Bases are machined, drilled and threaded for foot mounting on every standard model. Features to make installation and designing easier for you.



Quality high speed ball bearings are used on all smaller units. Heavy duty tapered roller bearings will give performance, durability for smooth operation and long life on larger units giving the assurance of solid performance for you or your customers.



All standard shafts use 4140 steel for trouble free operation. Input shafts are in sizes from the mini-series .626 inches [15,90 mm] to the SAE C-C 1.750 inches [44,45 mm].



Output shafts are in sizes from the Mini-Series .750 inches [19,05 mm] to the SAE C-C 1.750 inches [44,45 mm].



Spline shafts for input and output are available in several configurations depending on model size.



Hollow bore shafts are available on several models.



Instructions for mounting included.



Painted.









Gaskets/mounting seals provided for input.



See following catalog pages for complete dimensional, technical, operational and model numbers for making your selection.

Note:  
 Users must shield all moving parts and fill each with a proper lubricant.

# Table of Contents

Page #			
3	Selecting The Correct Von Ruden Overhung Load Adaptors (Bearing Blocks)		
4	Lubrication Requirements For Speed, Temperature and Mounting Positions		
5 - 6		Mini Series 2 Bolt with Standard Duty Ball Bearings	Use with hydraulic motor and pump applications with shaft diameters up to 5/8" in diameter and 2.5" pilot.
7 - 8		SAE "A" 2 Bolt with Standard Duty Ball Bearings	Use with hydraulic motor and pump applications with shaft diameters up to 1" in diameter and 3.25" pilot.
9 - 10		SAE "A" 2 Bolt with Heavy Duty Ball Bearings	Use with higher loads and larger shafts up to 1.25" in diameter and 3.25" pilot.
11 - 12		4 Bolt with 2.5" Pilot with Standard Duty Ball Bearings	For use with low speed high torque motors shafts up to 1" in diameter and 1.75" pilot.
13 - 14		SAE "A" 4 Bolt with Heavy Duty Tapered Bearings	Use with higher loads and larger input shafts up to 1.25" in diameter and 3.25" pilot.
15 - 16		SAE "B" 2/4 Bolt with Heavy Duty Tapered Bearings	Use with hydraulic motor and pump applications with shaft diameters up to 1.25" in diameter and 4.0" pilot.
17 - 18 19 - 20		SAE "C" & "CC" 2/4 Bolt with Heavy Duty Tapered Bearings	Use with hydraulic motor and pump applications with shaft diameters up to 1.75" in diameter and a 5.0" pilot.

# SELECTING THE CORRECT VON RUDEN OVERHUNG LOAD ADAPTOR (BEARING BLOCK)

1. Select the correct flange size, from SAE or other industry standard styles shown in this catalog. (For styles not shown in this catalog, call VON RUDEN for special units).

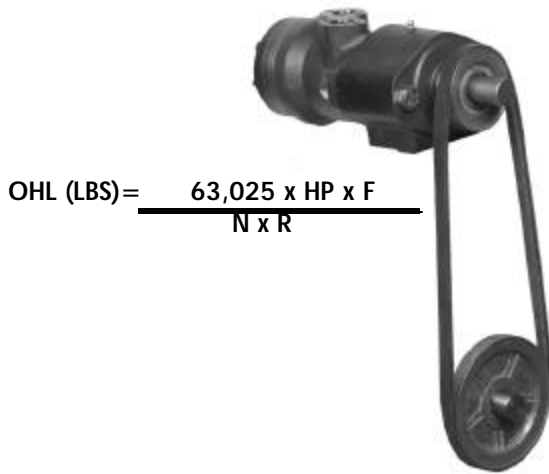

$$\text{OHL (LBS)} = \frac{63,025 \times \text{HP} \times \text{F}}{\text{N} \times \text{R}}$$

- HP = Transmitted horsepower
- N = RPM of shaft on adaptor
- R = Radius of sprocket, pulley or gear in inches
- F = Load connection factor (drives)
  - 1.0 Single chains
  - 1.10 Timing belts
  - 1.25 All gears or double chains
  - 2.5 Flat Belts

## Bearing Life Ratings (L<sub>10</sub>)

Rating Life, L<sub>10</sub>, is the life that 90 percent of a group of apparently identical bearings will complete or exceed before reaching a defined failure criteria. The average bearing life can reach 4 to 5 times the L<sub>10</sub> life. The unit of life is expressed in *hours*.

### Considerations when doing your calculation and application design.

When you double the SPEED, life is reduced by one-half, reducing SPEED one-half doubles the life. Double the LOAD, life is reduced to about 1/10th, reduce LOAD 1/2 and life increases ten times.

### Lubricants and/or lubricating systems as recommended by Timken Engineering Journal.

**Grease:** Lubrication may be used for continuous bearing speeds up to 2,500 FPM [762 MPM] rib speed. Grease lubrication has very limited capacity to dissipate heat. It is also difficult to provide a continuous supply of lubricant to the roller-rib contact at high speed operation.

**Static Oil:** This method of lubrication is used successfully for speeds up to 3,500 FPM [1,067 MPM] rib speed. Increased contact of lubricant with the housing results in an improved means of dissipating heat over grease lubrication.

**Forced Feed Oil Systems:** Bearing speeds above 5,000 FPM [1,524 MPM] rib speed generally require a circulating oil system. Because centrifugal forces tend to starve the roller-rib contact area of lubricant. The main problem with running faster is getting lubricant to where it is needed.

# LUBRICATION REQUIREMENTS FOR SPEED, TEMPERATURE AND MOUNTING POSITIONS.

**Lubrication requirements for speeds and temperatures.**  
**All Overhung Load Adaptors (Bearing Blocks) Are Shipped Without Lubrication.**

Speeds under 1800 RPM, use bearing grease, 80/90 wt. oil or circulating lube oil system.  
 Speeds 1800 or 2400 RPM, use low viscosity oil or circulating lube oil system.  
 Speeds over 2400 RPM require circulating lube oil systems and possible coolers.

<u>Ambient Temperature</u>	<u>Lubricant</u>
(-20° F to 0° F)	Mobile Super 10W-30
(0° F to 40° F)	Mobilelube HD 80W-90
(40° F to 100° F)	Mobilelube HD 80W-90
(100° F to 150° F)	Mobilelube HD 85W-140

<u>Model Series</u>	<u>Description</u>	<u>Recommended Amount in Horizontal Position</u> (See special mounting note below)	<u>Maximum Displacement/Volume</u>
Mini Series	2 Bolt with Standard Duty Ball Bearings	1.50 oz. [.044 Liters]	5.42 Cubic Inches/3.00 oz. [88.83 Cubic Centimeters]
SAE 'A'	2 Bolt with Standard Duty Ball Bearings	1.70 oz. [.050 Liters]	6.00 Cubic Inches/3.40 oz. [98.34 Cubic Centimeters]
SAE 'A'	2 Bolt with Heavy Duty Ball Bearings	1.25 oz. [.037 Liters]	4.50 Cubic Inches/2.5 oz. [73.75 Cubic Centimeters]
Special Industry Standard	4 Bolt with 2.5 inch Pilot with Standard Duty Ball Bearings	1.70 oz. [.050 Liters]	6.00 Cubic Inches/3.40 oz. [98.34 Cubic Centimeters]
SAE 'A'	4 Bolt with Heavy Duty Tapered Bearings	2.35 oz. [.069 Liters]	8.63 Cubic Inches/4.70 oz. [141.45 Cubic Centimeters]
SAE 'B'	2/4 Bolt with Heavy Duty Tapered Bearings	2.35 oz. [.069 Liters]	8.63 Cubic Inches/4.70 oz. [141.45 Cubic Centimeters]
SAE 'C'	2/4 Bolt with Heavy Duty Tapered Bearings	3.44 oz. [.102 Liters]	12.40 Cubic Inches/6.88 oz. [203.24 Cubic Centimeters]
SAE 'C-C'	2/4 Bolt with Heavy Duty Tapered Bearings	4.25 oz. [.125 Liters]	15.30 Cubic Inches/8.50 oz. [250.77 Cubic Centimeters]

### **Special Mounting Note**

When mounting the overhung load adaptor (Bearing Block) in the vertical position or any other position that the shaft is at a 30° or greater tilt, a forced feed oil system is recommended. If that is not an option, an outside vented reservoir with sufficient lubricant capacity connected to one of the fill ports that has an oil level above the highest bearing may offer proper lubrication if speeds are within parameters listed above in recommended lube specifications.

**Mini Series 2 - Bolt With Standard Duty Ball Bearings**

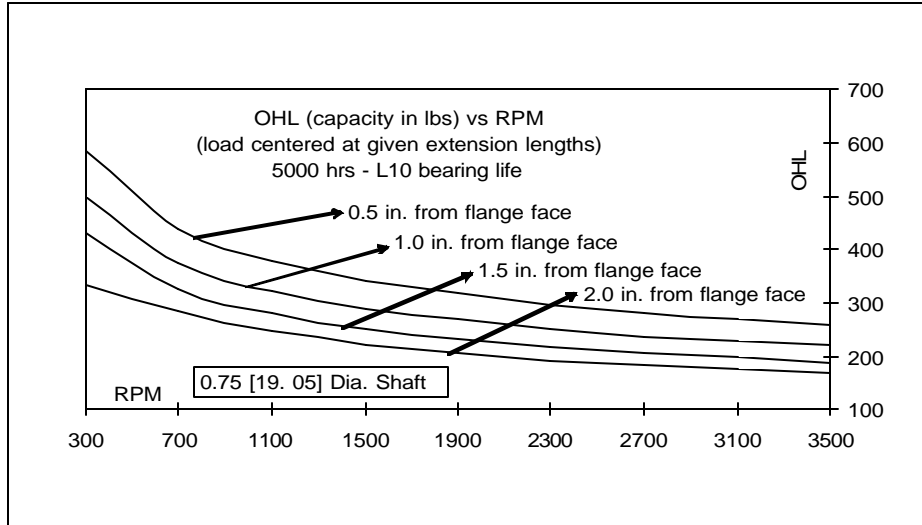

**Ordering Information**

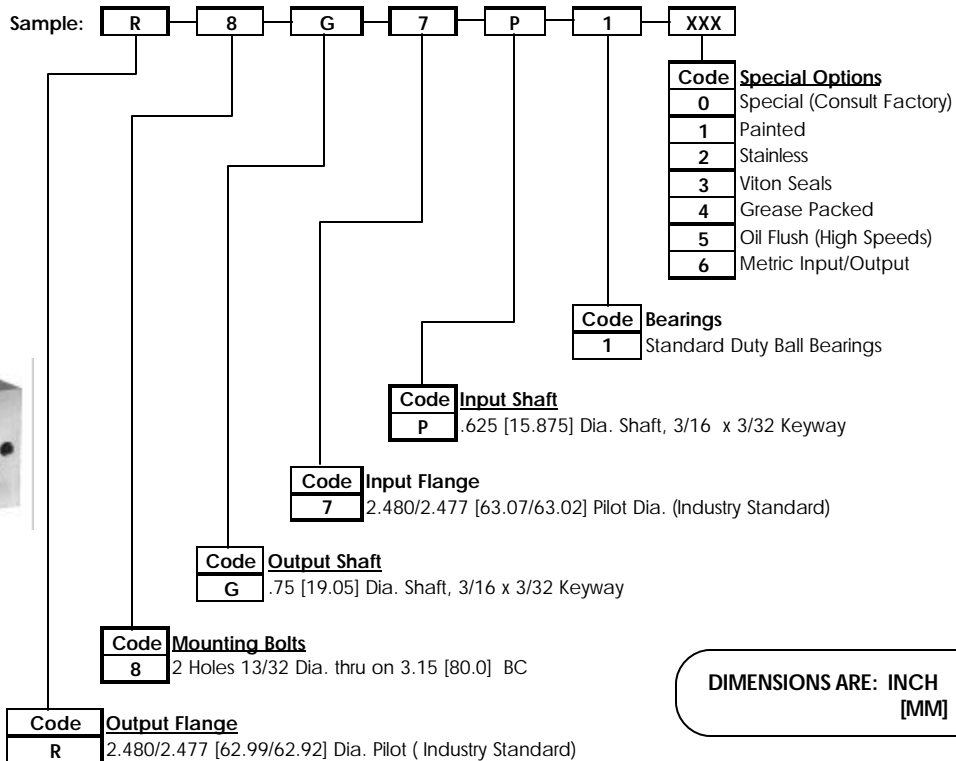

For Other Options: Contact Von Ruden Manufacturing, Inc.

**Mini Series 2 - Bolt  
With Standard Duty Ball Bearings**

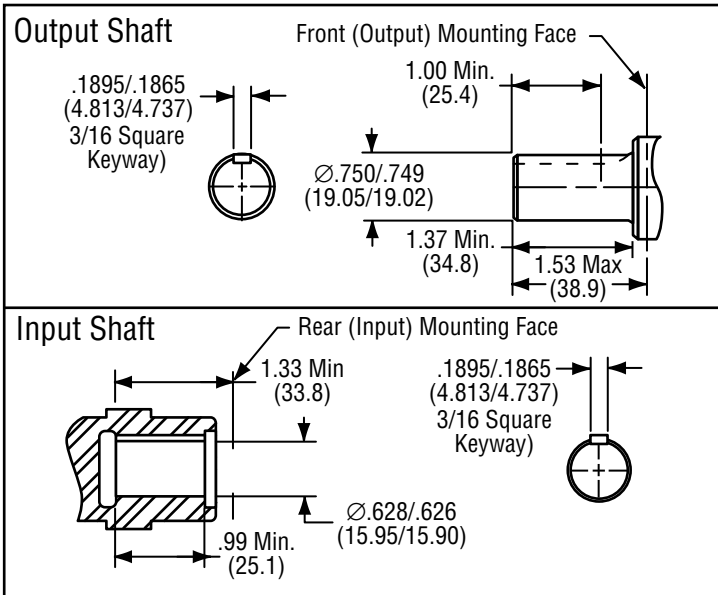
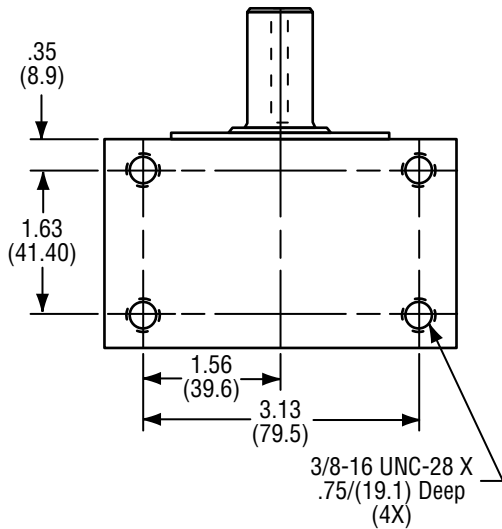
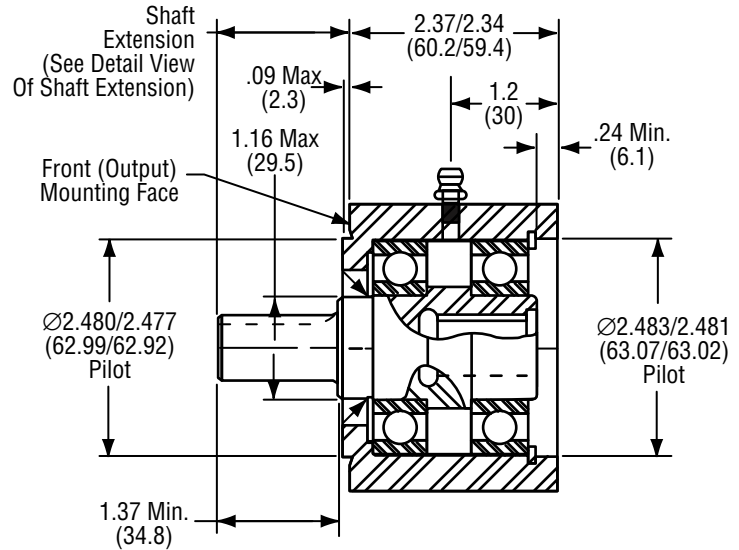
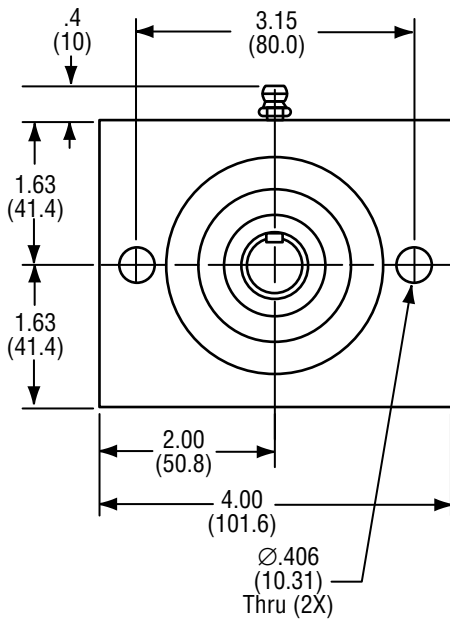
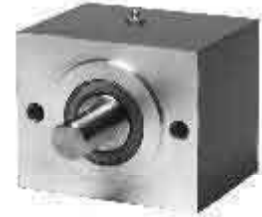

Dimensions Are: Inch (MM)

T155869

Approximate Wt. 6 lbs. [2.72 kg.]

## SAE "A" 2 BOLT FLANGE With Standard Duty Ball Bearings

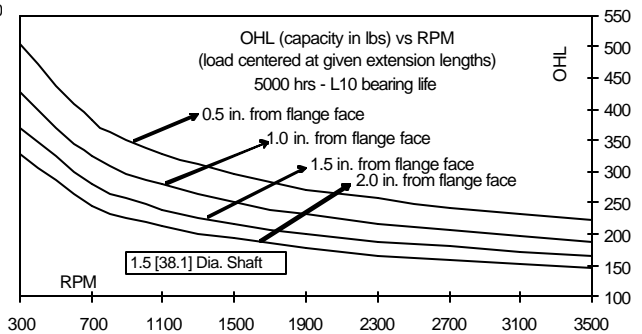
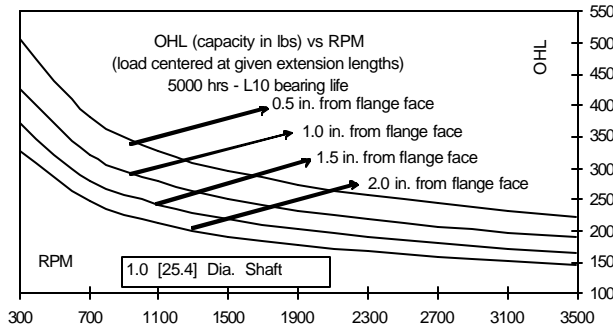

### Ordering Information

Sample: **A** **2** **A** **1** **C** **1** **XXX**

Code	Special Options
0	Special (consult factory)
1	Painted
2	Stainless
3	Viton Seals
4	Grease Packed
6	Metric Input/Output

Code	Bearings
1	Standard Duty Ball Bearings

Code	Input Shaft
C	1.00 [25,4] Dia. Shaft, 1/4 x 1/8 Keyway
G	0.75 [19,05] Dia. Shaft, 3/16 x 3/32 Keyway
X	Hollow thru Shaft, see output shaft code

Code	Input Flange
1	SAE "A" Flange (Order spacer #11351 when 1/8" deep pilot is require)

Code	Output Shaft
A	1.00 [25,4] Dia. Shaft, 1/4 x 1/8 Keyway
C	1.50 [38,1] Dia Shaft, 3/8 x 3/16 Keyway
D	1.00 ID (Hollow) thru Shaft, 1/4 x 1/8 Keyway
G	0.75 [19,05] Dia. Shaft, 3/16 x 3/32 Keyway

DIMENSIONS ARE: INCH  
[MM]

Code	Mounting Bolts
2	2 Holes 17/32 Dia. thru on 4-3/16 [106,363] BC

Code	Output Flange
A	SAE "A" FLANGE

For Other Options: Contact Von Ruden Manufacturing, Inc.

## SAE "A" 2 BOLT FLANGE With Standard Duty Ball Bearings

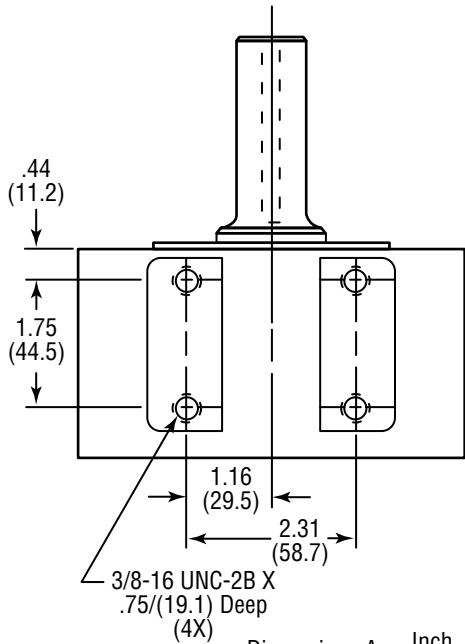
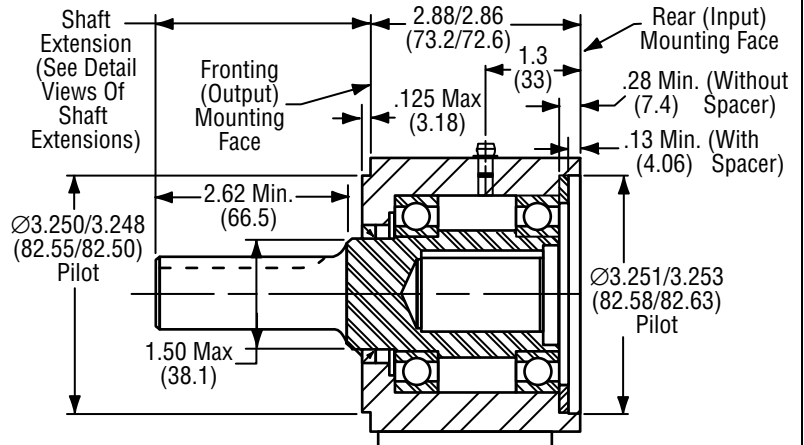
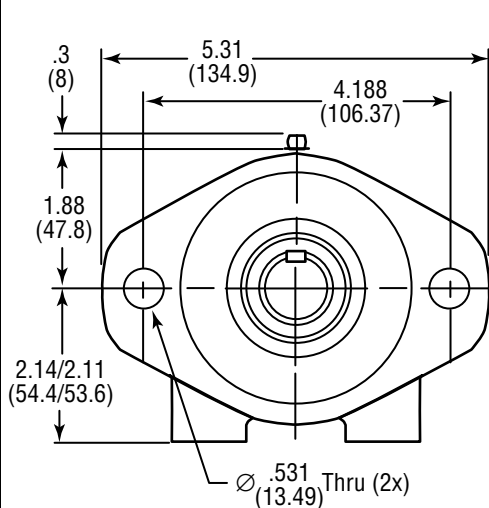

Dimensions Are: Inch (MM)

T155751  
 Approximate Wt. 10 lbs. [4.53 kg.]

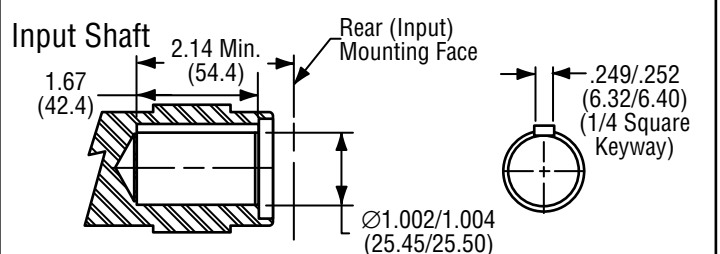
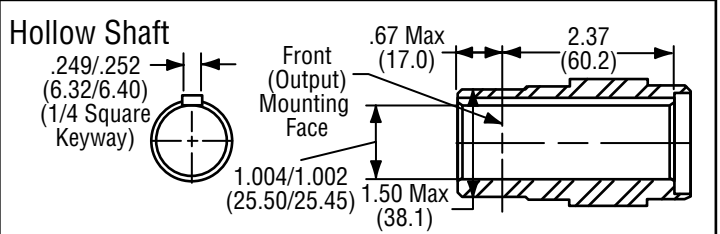
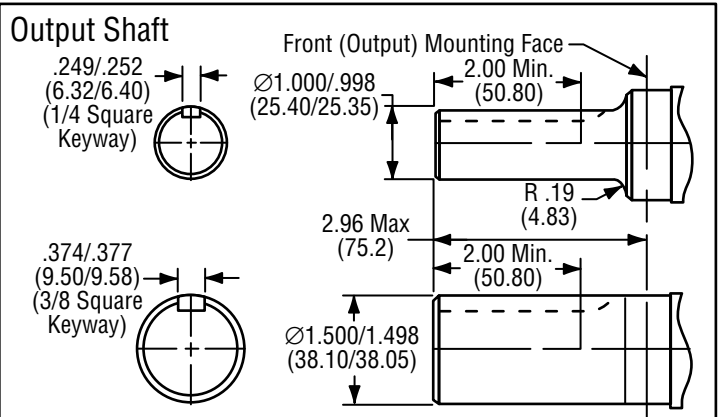

## SAE "A" 2 BOLT FLANGE With Heavy Duty Ball Bearings

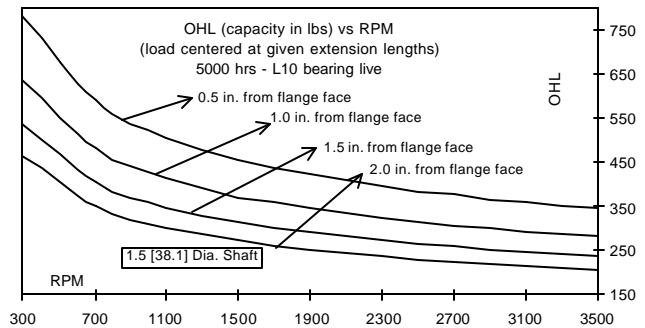
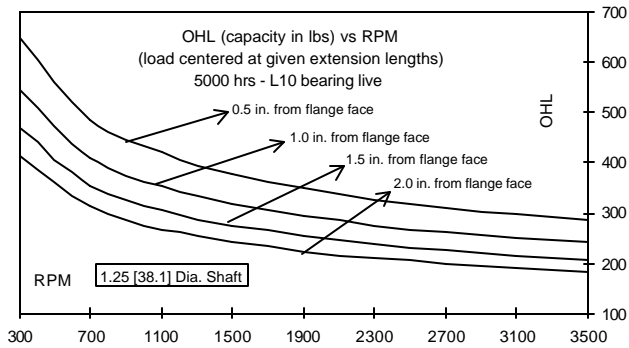

### Ordering Information

Sample: A 2 B 1 B 2 XXX

Code	Special Options
0	Special (consult factory)
1	Painted
2	Stainless
3	Viton Seals
4	Grease Packed
5	Oil Flush (High Speeds)
6	Metric Input/Output

Code	Bearings
2	Heavy Duty Ball Bearings

Code	Input Shaft
B	1.25 [31,8] Dia. Shaft, 5/16 x 5/32 Keyway
C	1.50 [38,1] Dia Shaft, 3/8 x 3/16 Keyway
X	Hollow thru Shaft, see output shaft code

Code	Input Flange
1	SAE "A" Flange

Code	Output Shaft
B	1.25 [31,75] Dia. Shaft, 5/16 x 5/32 Keyway
C	1.50 [38,1] Dia Shaft, 3/8 x 3/16 Keyway
E	1.25 ID (Hollow) thru Shaft, 5/16 x 5/32 Keyway thru

Code	Mounting Bolts
2	2 Holes 17/32 [5,556] Dia. thru on 4-3/16 [106,363] BC

Code	Output Flange
A	SAE "A" FLANGE

DIMENSIONS ARE: INCH  
[MM]

For Other Options: Contact Von Ruden Manufacturing, Inc.

## SAE "A" 2 BOLT FLANGE With Heavy Duty Ball Bearings

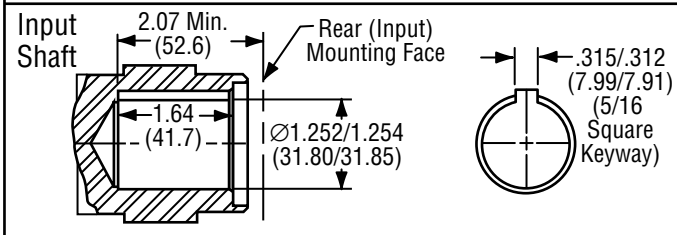
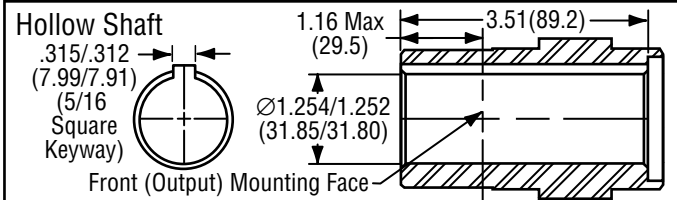
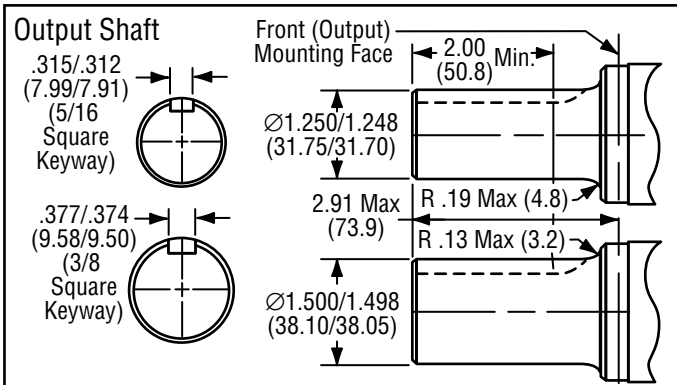
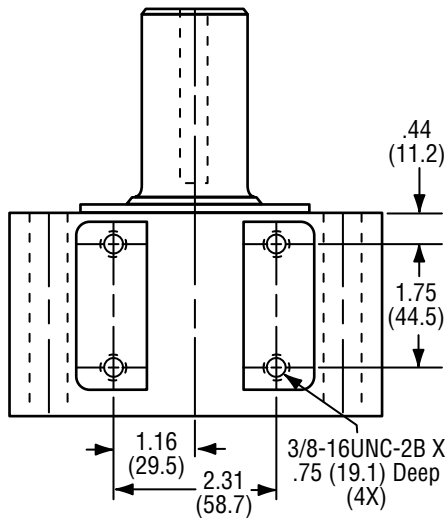
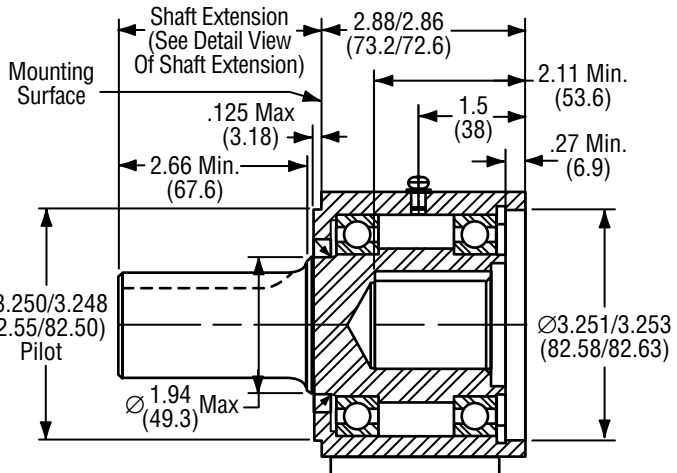
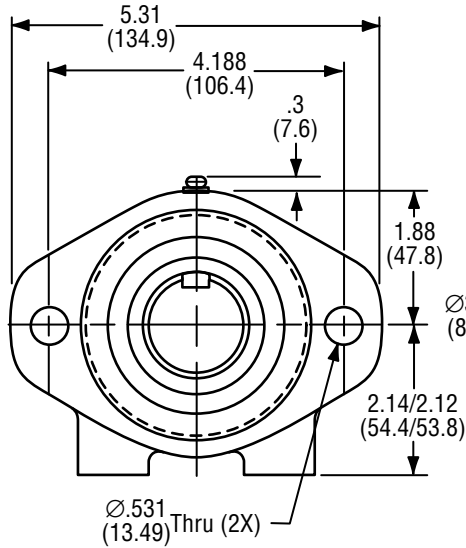

TI55749

Dimensions Are: Inch (MM)  
Approximate  
Wt. 11 lbs. [4.99 kg.]

**Model 4 Bolt, 2.5" Pilot With Standard Duty Ball Bearings**

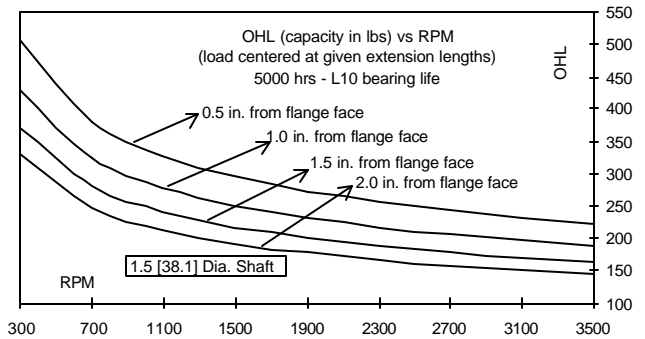
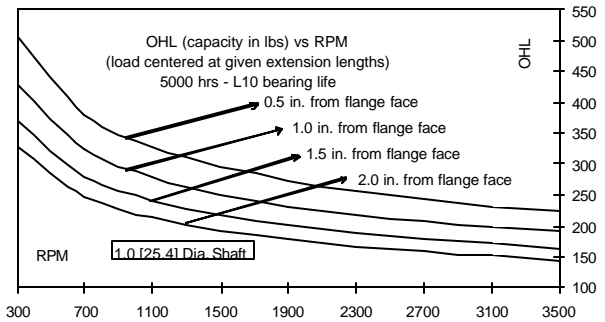

**Ordering Information**

Sample: **Q** - **3** - **D** - **5** - **C** - **1** - **XXX**

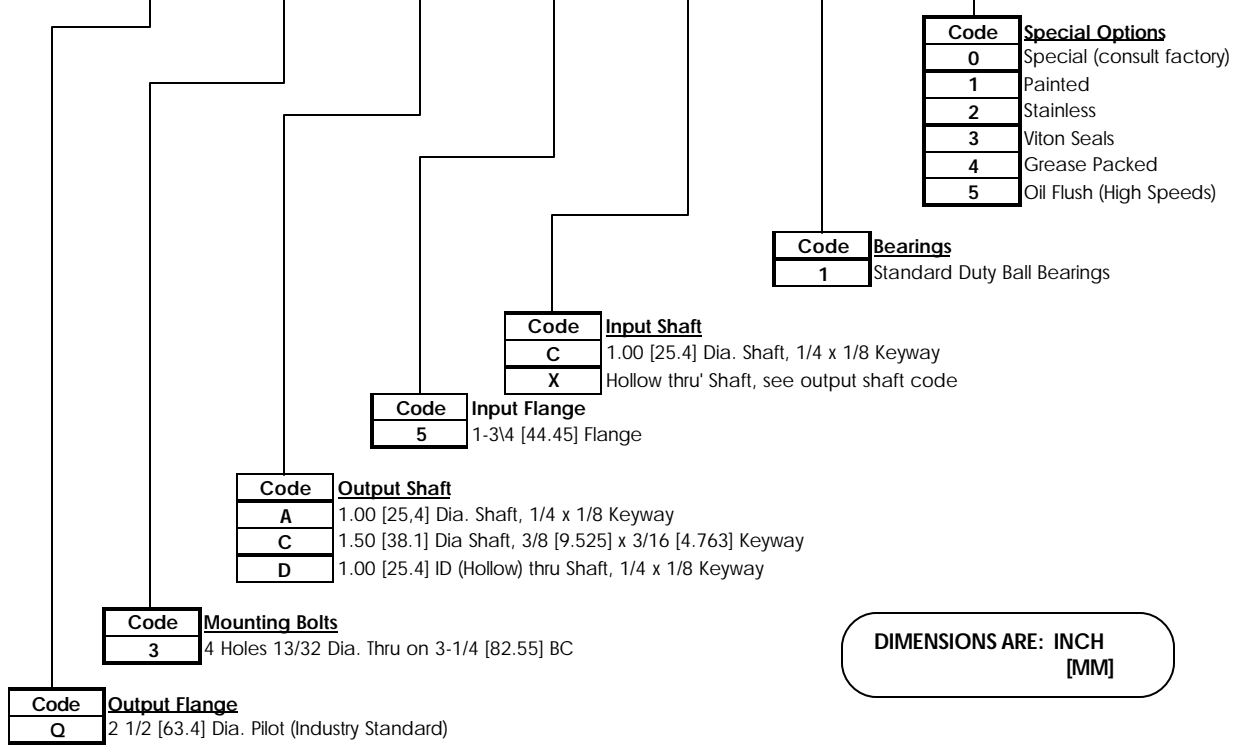

**DIMENSIONS ARE: INCH [MM]**

For Other Options: Contact Von Ruden Manufacturing, Inc.

## Model 4 Bolt, 2.5" Pilot With Standard Duty Ball Bearings

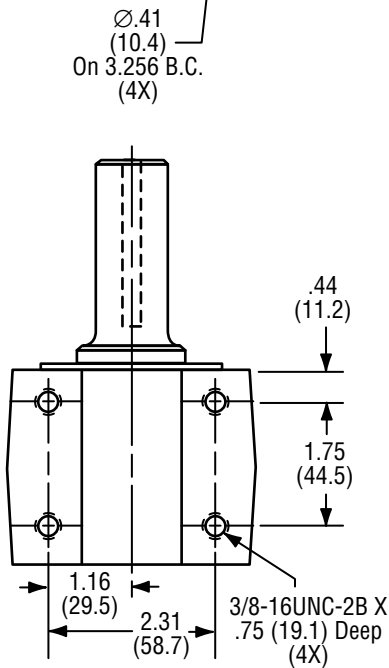
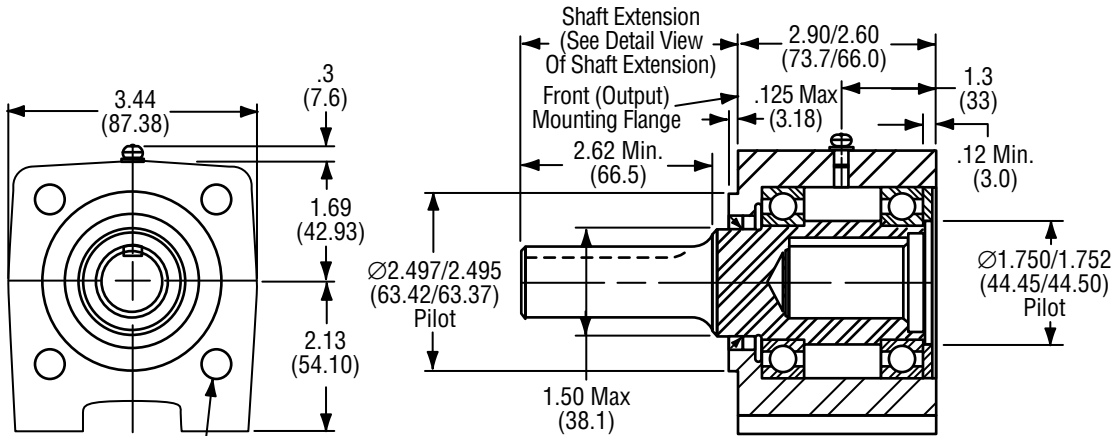

Dimensions Are: Inch (MM)

T155750

Approximate  
Wt. 10 lbs. [4.53 kg.]

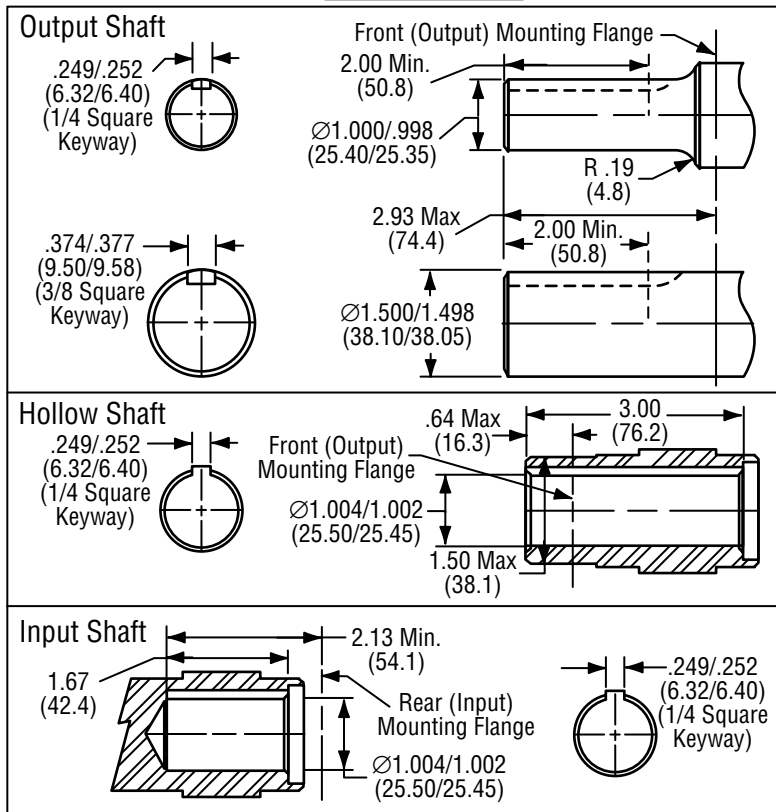

**SAE "A" 4 BOLT FLANGE With Heavy Duty Tapered Bearings**

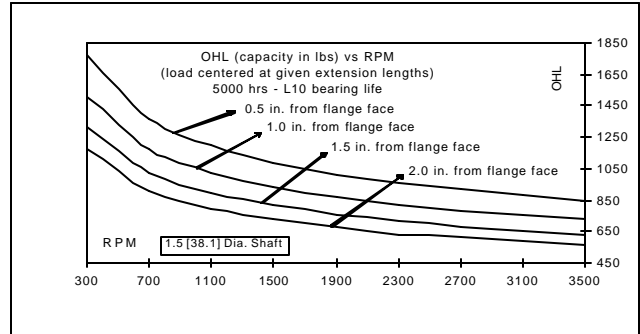
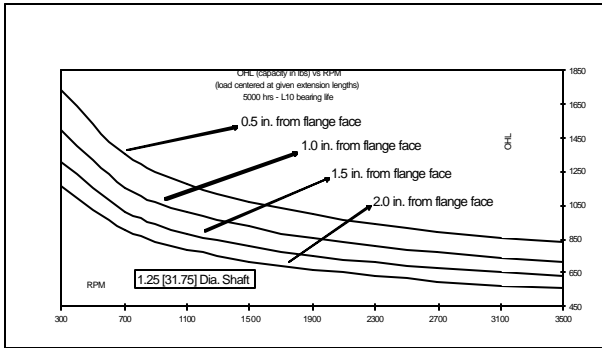

**Ordering Information**

Sample: **A** **7** **B** **1** **F** **3** **XXX**

<p><b>Code</b> <b>Special Options</b></p> <p><b>0</b> Special (Consult Factory)</p> <p><b>1</b> Painted</p> <p><b>2</b> Stainless</p> <p><b>3</b> Viton Seals</p> <p><b>4</b> Grease Packed</p> <p><b>5</b> Oil Flush (High Speeds)</p> <p><b>6</b> Metric Input/Output</p>	<p><b>Code</b> <b>Bearings</b></p> <p><b>3</b> Heavy Duty Tapered Bearings</p>	<p><b>Code</b> <b>Input Shaft</b></p> <p><b>K</b> 1.00 [25,4] Dia. Shaft, SAE 6B Spline</p> <p><b>B</b> 1.25 [31,85] Dia. Shaft, 5/16 x 5/32 Keyway</p> <p><b>F</b> 1.25 [31,85] 14 Tooth 12/24 Spline</p> <p><b>X</b> Hollow Thru' Shaft, see output shaft code</p>	<p><b>Code</b> <b>Input Flange</b></p> <p><b>1</b> SAE A Flange</p>	<p><b>Code</b> <b>Output Shaft</b></p> <p><b>B</b> 1.25 [31,85] Dia. Shaft, 5/16 x 5/32 Keyway</p> <p><b>C</b> 1.50 [38,1] Dia. Shaft, 3/8 x 5/32 Keyway</p> <p><b>F</b> 1.375 [34,93] Dia. Shaft, 5/16 x 5/32 Keyway</p>	<p><b>Code</b> <b>Mounting Bolts</b></p> <p><b>7</b> 4 Holes both sides 1/2-13 UNC (Magneto Mount)</p>	<p><b>Code</b> <b>Output Flange</b></p> <p><b>A</b> SAE "A" FLANGE</p>
---	--	--	---	---	--	--

DIMENSIONS ARE: INCH [MM]

For Other Options: Contact Von Ruden Manufacturing, Inc.



## Model SAE "B" 2/4 Bolt With Heavy Duty Tapered Bearings

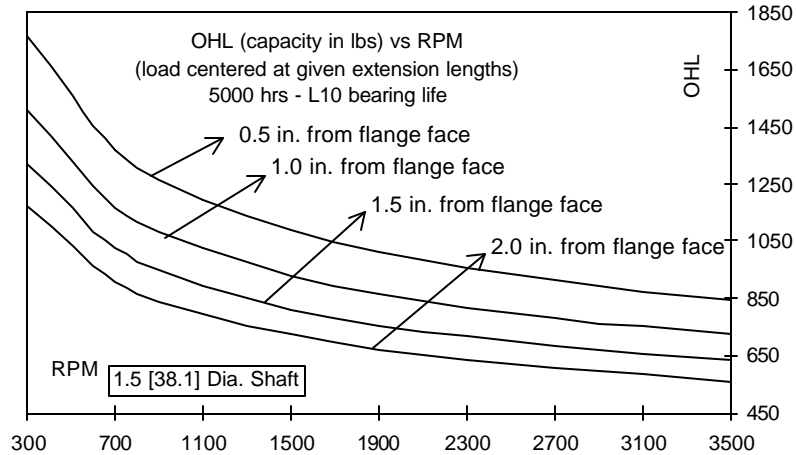

### Ordering Information

Sample: **B** - **4** - **C** - **2** - **B** - **3** - **XXX**



Code	Special Options
0	Special (Consult Factory)
1	Painted
2	Stainless
3	Viton Seals
4	Grease Packed
5	Oil Flush (High Speeds)
6	Metric Input/Output

Code	Bearings
3	Heavy Duty Tapered Bearings

Code	Input Shaft
B	1.25 [31.85] Dia. Shaft, 5/16 x 5/32 Keyway
C	1.00 [25.4] Dia. Shaft, 1/4 x 1/8 Keyway
D	.875 [22.0] Dia. Shaft, 1/4 x 1/8 Keyway
E	13 Tooth 16/32 Spline
F	15 Tooth 16/32 Spline
G	14 Tooth 12/24 Spline
X	Hollow thru Shaft, see output shaft code

Code	Input Flange
2	SAE B Flange

Code	Output Shaft
C	1.50 [38.1] Dia. Shaft, 3/8 x 3/16 Keyway
D	1.00 ID (Hollow) thru Shaft, 1/4 x 1/8 Keyway

Code	Mounting Bolts
4	6 Holes 9/16 Dia. thru on 5 [127.00] & 5-3/4 [146.05] BC's

Code	Output Flange
B	SAE "B" FLANGE

DIMENSIONS ARE: INCH  
[MM]

For Other Options: Contact Von Ruden Manufacturing, Inc.

## Model SAE "B" 2/4 Bolt With Heavy Duty Tapered Bearings



Overhung Load Adaptors (Bearing Blocks)

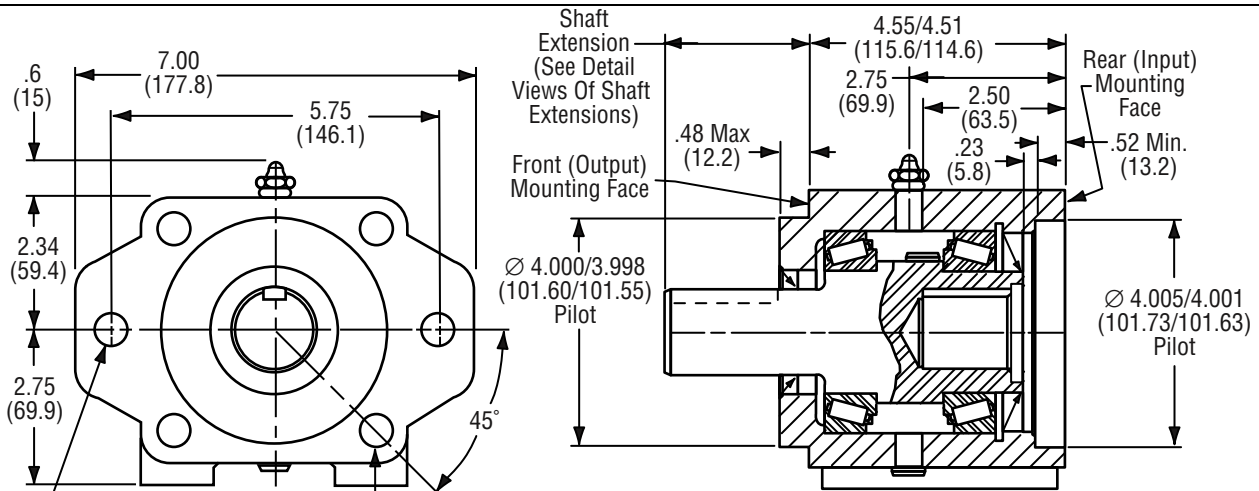

$\varnothing$  .56 Thru (2X)  $\varnothing$  .56 (14.2)  
 $\varnothing$  .56 (14.2)  
 On  $\varnothing$  5.00 B.C. (127.0) (4X)

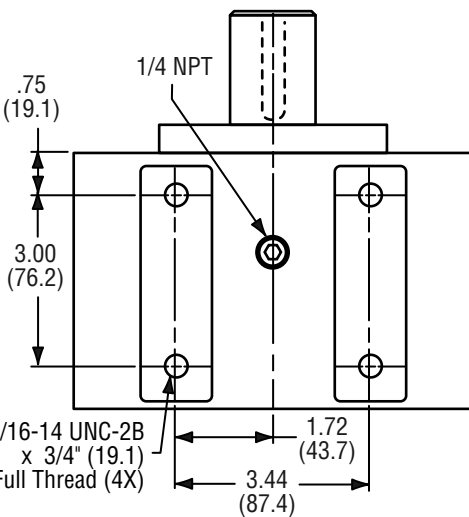

7/16-14 UNC-2B  
 x 3/4" (19.1)  
 Full Thread (4X)

Dimensions Are: Inch (MM)

T155857

Approximate  
Wt. 30 lbs. [13.61 kg.]

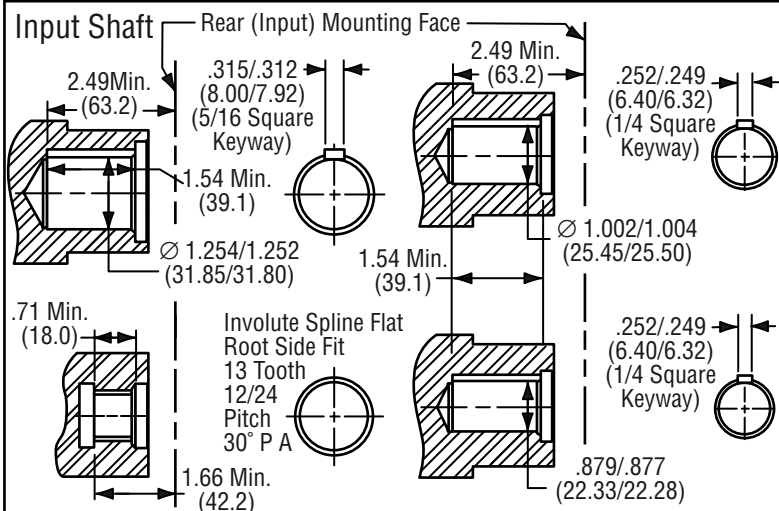
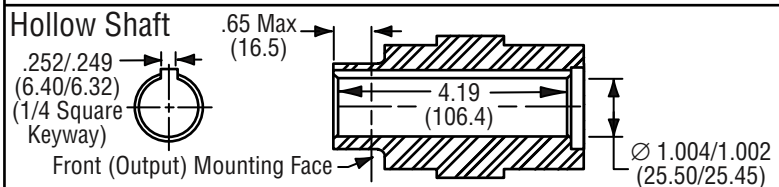
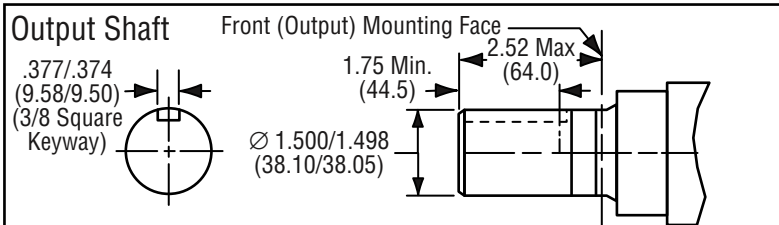

## SAE "C" 2/4 BOLT FLANGE With Heavy Duty Tapered Bearings

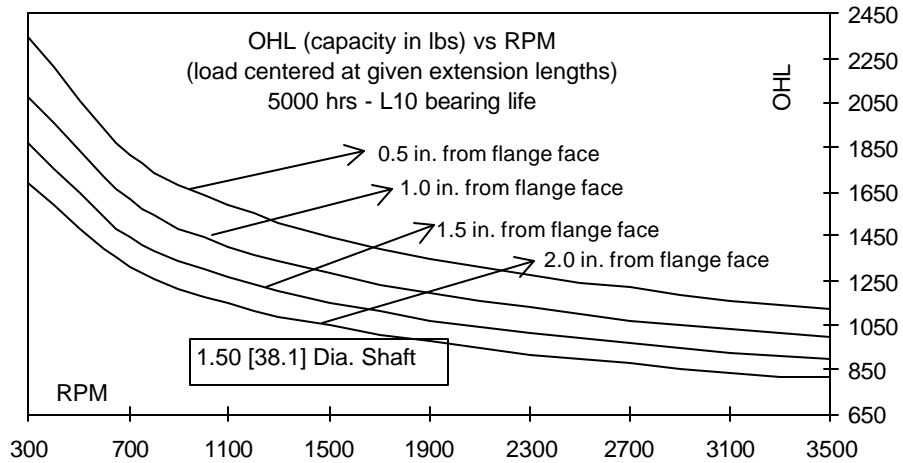

### Ordering Information

Sample: C - 6 - C - 3 - B - 3 - XXX

	Code	<b>Special Options</b>	
0	Code	Special (Consult Factory)	
1	Code	Painted	
2	Code	Stainless	
3	Code	Viton Seals	
4	Code	Grease Packed	
5	Code	Oil Flush (High Speeds)	
6	Code	Metric Input/Output	

	Code	<b>Bearings</b>	
3	Code	Heavy Duty Tapered Bearings	

	Code	<b>Input Shaft</b>	
B	Code	1.25 Dia. Shaft, 5/16 x 5/32 Keyway	
C	Code	1.00 Dia. Shaft, 1/4 x 1/8 Keyway	
D	Code	.875 Dia. Shaft, 1/4 x 1/8 Keyway	
F	Code	14 Tooth 12/24 Spline	
X	Code	Hollow thru Shaft, see output shaft code	

	Code	<b>Input Flange</b>	
3	Code	SAE C Flange	

	Code	<b>Output Shaft</b>	
C	Code	1.50 Dia Shaft, 3/8 x 3/16 Keyway	
D	Code	1.00 ID (Hollow) thru Shaft, 1/4 x 1/8 Keyway thru	

	Code	<b>Mounting Bolts</b>	
6	Code	6 Holes thru, 4 @ 9/16 Dia on 6-3/8 BC & 2 @ 11/16 Dia on 7-1/8 BC	

	Code	<b>Output Flange</b>	
C	Code	SAE "C" FLANGE	



DIMENSIONS ARE: INCH  
[MM]

For Other Options: Contact Von Ruden Manufacturing, Inc.

## SAE "C" 2/4 BOLT FLANGE With Heavy Duty Tapered Bearings

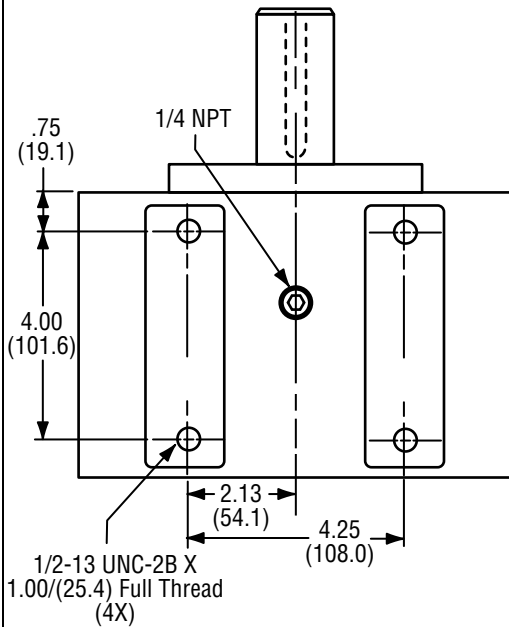
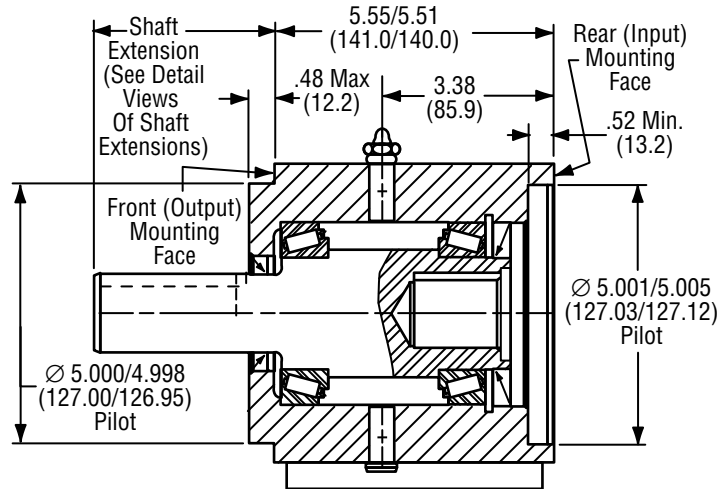
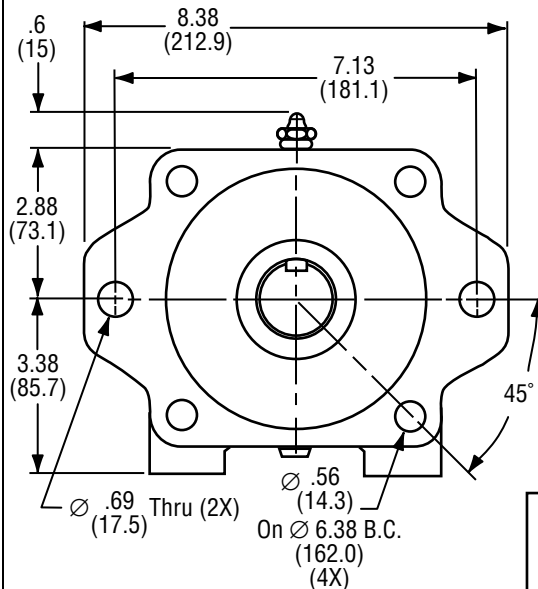

Dimensions Are: Inch (MM)

T155865

Approximate Wt. 55 lbs. [24.95 kg.]

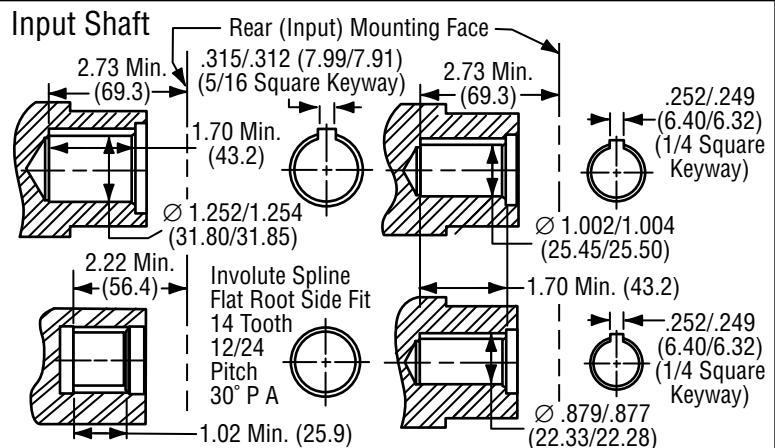
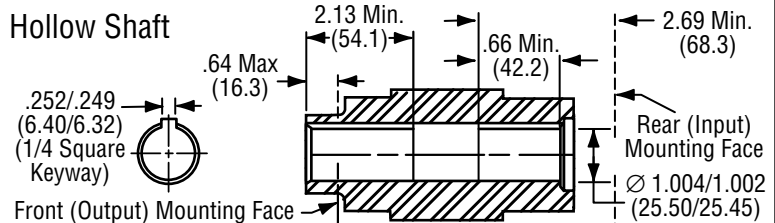
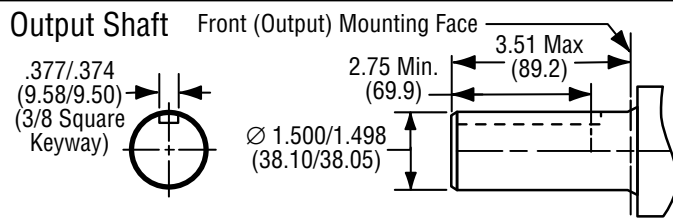

## Model SAE "C-C" With Heavy Duty Tapered Bearings

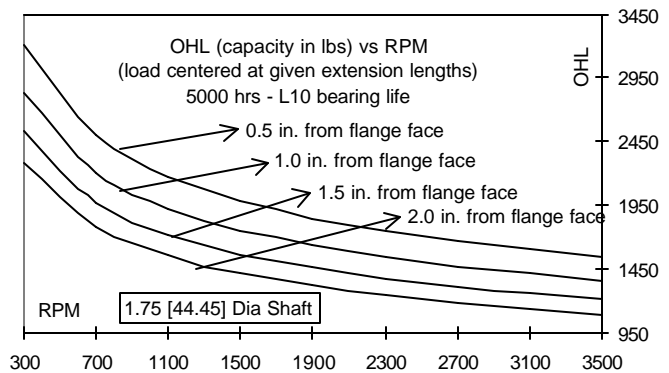
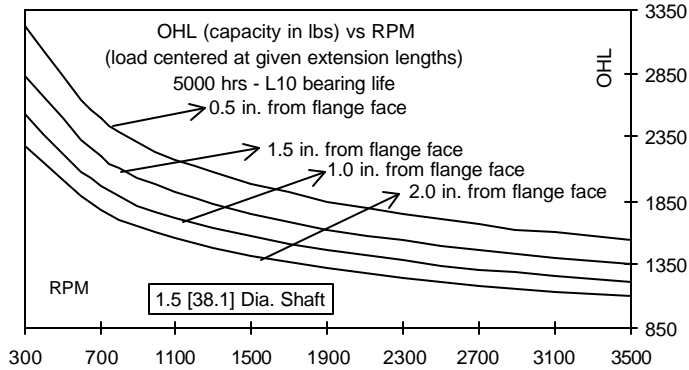

### Ordering Information

Sample: **E** - **6** - **F** - **6** - **H** - **3** - **XXX**

Code	Special Options
0	Special (Consult Factory)
1	Painted
2	Stainless
3	Viton Seals
4	Grease Packed
5	Oil Flush (High Speeds)
6	Metric Input/Output

Code	Bearings
3	Heavy Duty Tapered Bearings

Code	Input Shaft
F	14 Tooth 12/24 Spline
G	1.50 [38.1] Dia. Shaft, 3/8 x 3/16 Keyway
H	1.75 [44.45] Dia. Shaft, 7/16 x 7/32 Keyway
J	17 Tooth 12/24 Spline

Code	Input Flange
6	SAE C-C Flange

Code	Output Shaft
C	1.50 [38.1] Dia. Shaft, 3/8 x 3/16 Keyway
F	1.75 [44.45] Dia. Shaft, 7/16 x 7/32 Keyway

DIMENSIONS ARE: INCH  
[MM]

Code	Mounting Bolts
6	6 Holes thru, 4 @ 9/16 on 6-3/8 [162.0] BC & 2 @ 11/16 dia. on 7-1/8 [181.0] BC

Code	Output Flange
E	SAE "C-C" FLANGE

**For Other Options: Contact Von Ruden Manufacturing, Inc.**

## Model SAE "C-C" With Heavy Duty Tapered Bearings

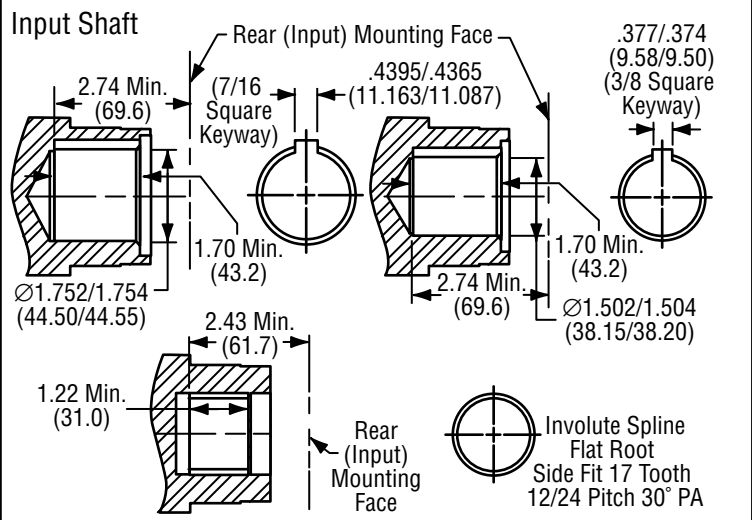
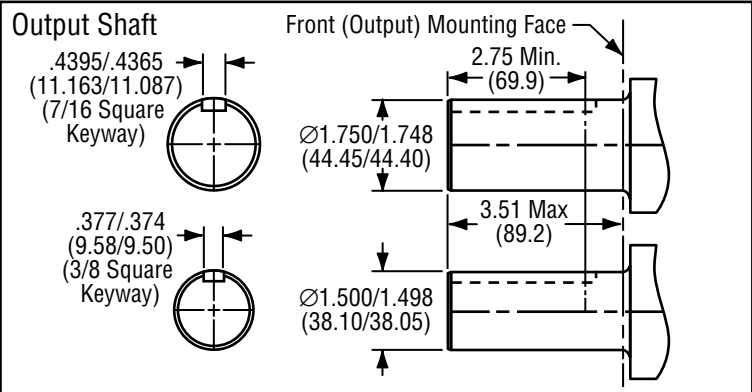
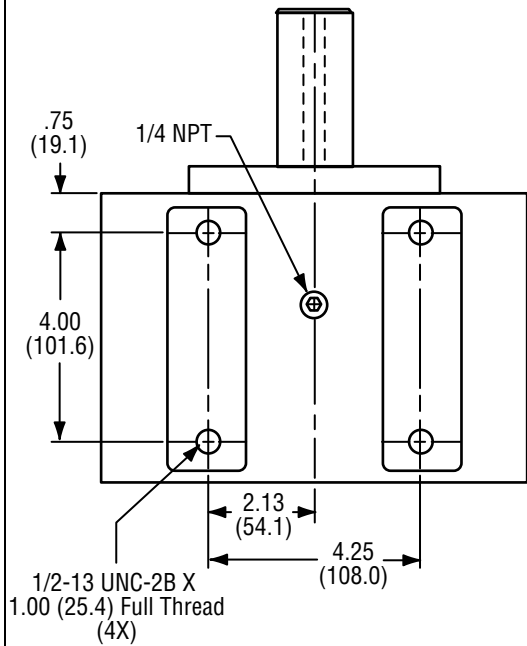
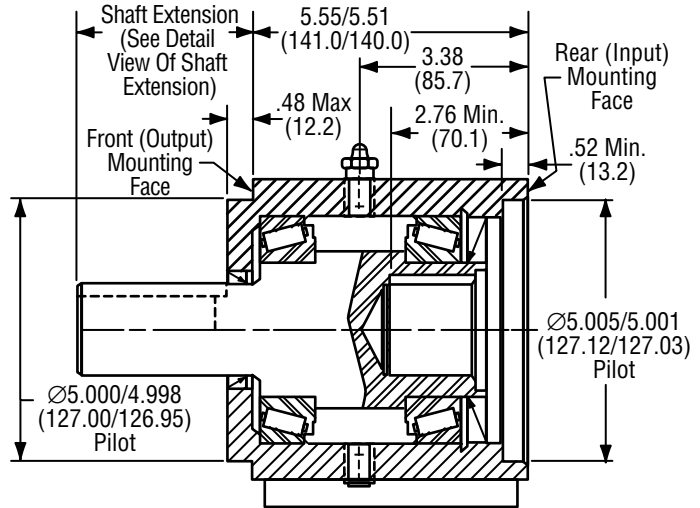
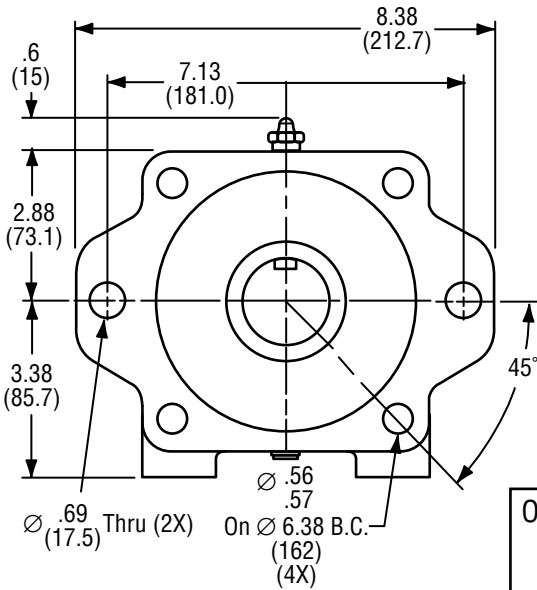

Dimensions Are: Inch (MM)

T155866

Approximate Wt. 55 lbs. [24.95 kg.]