

Bevel Gear Boxes

A GENERAL OVERVIEW

For Complete Specifications & Comprehensive Performance Data on All Bevel Gear Box Models see www.vonruden.com.



07.08.03



Any discussion of **Bevel Gear Boxes** must first clarify the definition of **Beveled Gears**.

A bevel gear is made in the shape of a cone. Deployed in pairs, they are used to connect intersecting shafts. Normally they are mounted on shafts that are at 90° to each other (hence the term "right angle" bevel gears). However, they are not restricted to 90° mounting.



Typical set of bevel gears meshed at 90°

Nomenclature of a Typical Bevel Gear Box.

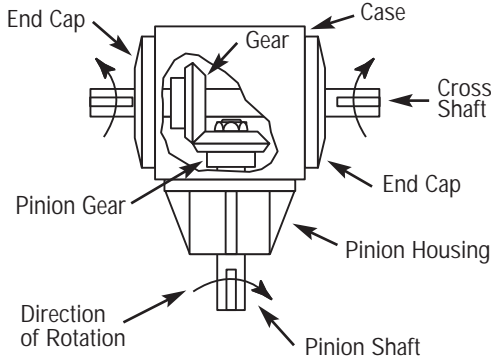

Primary Purposes:

The primary purposes of bevel gear boxes are illustrated here. Two or more purposes are frequently accomplished simultaneously. For example: To transmit power at 90° AND decrease speed/increase torque.

Transmitting Power At 90°

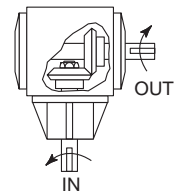

Splitting Power

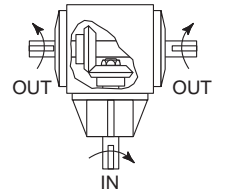

Decreasing Speed & Increasing Torque

IN: 200 rpm & 500 lb-inches
OUT: 100 rpm & 1000 lb-inches
2:1 Reduction

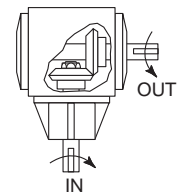

Increasing Speed & Decreasing Torque

IN: 200 rpm & 500 lb-inches
OUT: 400 rpm & 250 lb-inches
1:2 Speed-Up

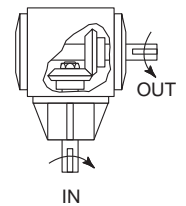

Functioning as a Power Take-off Device with the Cross-shaft as a Common Input

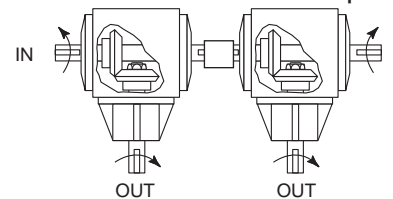

Von Ruden Standard Bevel Gear Box Overview

Model	Pinion Shaft Diameter (inches)	Maximum Input speed (rpm)	Maximum Input Horsepower	Available Gear Reduction Ratios	Available Speed UP Ratios	Gear Types Available
15	.625	3000	18	1:1 1.5:1 2:1	1:1.5 1:2	Straight Cut Spiral
25	.75	3000	36	1:1 1.5:1 2:1	1:1.5 1:2	Straight Cut Spiral
27	1.0	3000	32	1:1 1.5:1 2:1 3:1	1:1.5 1:2 1:3	Straight Cut Spiral
33	1.0	3000	69	1:1 1.5:1 2:1	1:1.5 1:2	Forged Straight Cut Spiral
40	1.0	3000	69	1:1 1.5:1 2:1	1:1.5 1:2	Forged Straight Cut Spiral
90	1.25	2800	87	1:1 1.5:1 2:1	1:1.5 1:2	Forged Straight Cut Spiral
93	1.375	2500	149	1:1 1.5:1 2:1	1:1.5 1:2 1:3	Forged Straight Cut Spiral
110	1.5	1750	175	1:1 1.5:1 2:1	1:1.5	Forged Straight Cut Spiral
113	1.75 (2.0 opt)	1750	202	1:1 1.5:1 2:1 3:1	1:1.5 1:2 1:3	Forged Straight Cut Spiral

Bevel Gear Boxes TYPICAL CONFIGURATIONS

For Complete Specifications & Comprehensive Performance Data on All Bevel Gear Box Models see www.vonruden.com.



07.08.03

Cross Shaft Extensions

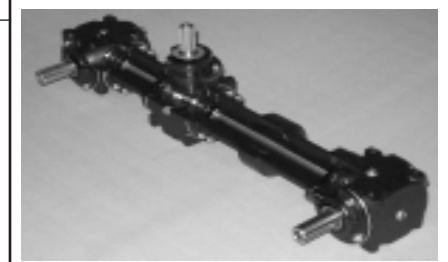
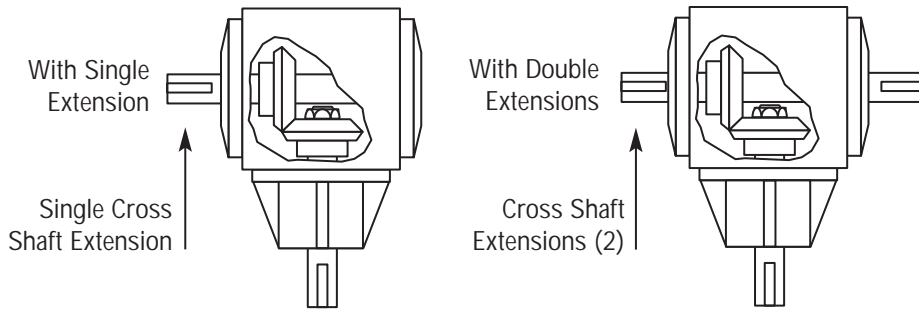

Experience Leads to Innovation...
Like this blade drive gearbox for commercial outfront, zero-turn, lawnmowers

Cross Shaft Direction of Rotation

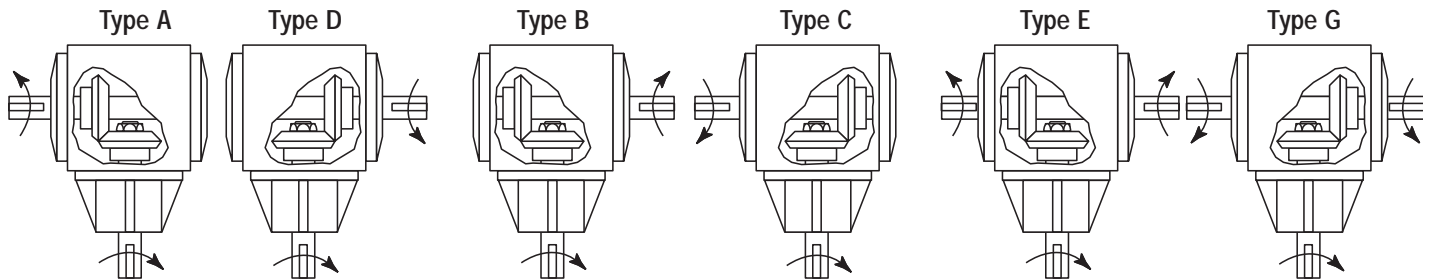

Types A and D are the same gear box turned over. Note the gear is **next** to the cross shaft extension (causing CCW rotation of the cross shaft).

Types B and C are the same gear box turned over. Note the gear is **opposite** to the cross shaft extension (causing CW rotation of the cross shaft).

Types E and G are also the same gear box turned over. In some cases (for higher reduction ratios) the cross shaft extension nearest the gear will be smaller in diameter than the other extension. This is to accommodate gear installation.

Other Configuration Possibilities

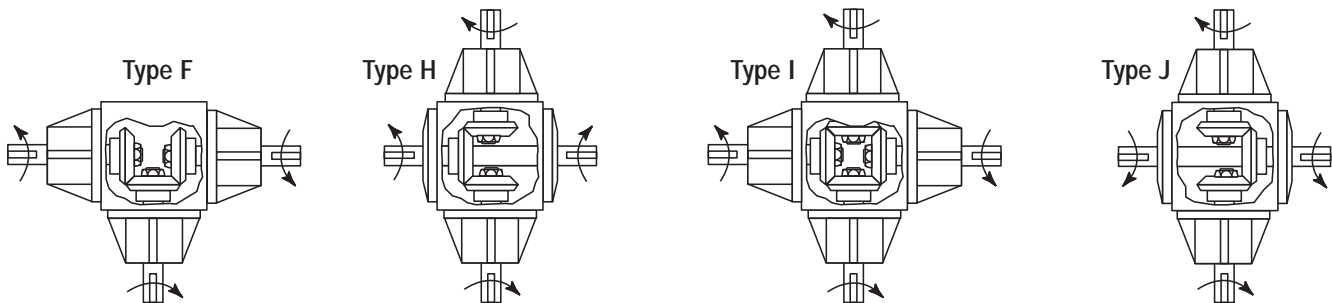

Gear Reduction Ratio

The term "gear reduction" applies to **speed**. A 2:1 reduction means that the speed will be reduced by a factor of two, or in other words, to 50%.

Obviously, if the the gear reduction reduces speed by 50%, the resulting torque will be **doubled**.

Example:

Gear Ratio	2:1
Input Speed	150 rpm
Output Speed	$150/2 = 75$ rpm
Input Torque	1000 lb.-inches
Output Torque	$1000 \times 2 = 2000$ lb.-inches

In all current VonRuden bulletins, the ratio is determined from the pinion shaft to the cross shaft.

The cross shaft can be used as the input shaft. In such cases the ratio would be simply reversed. A 2:1 reducer would become a 1:2 speed increaser.

Bevel Gear Boxes

WHY CHOOSE VON RUDEN?

For Complete Specifications & Comprehensive Performance Data on All Bevel Gear Box Models see www.vonruden.com.



07.08.03

Tailored to the Needs of a Design Engineer.

Selection:

- Models up to 200 hp.
- Choices of gear types and ratios.
- Speed reducing and increasing models.
- Direction of rotation options.
- Hydraulic motor input flange option.
- Configuration options.

Extended Working Life

- Press-fit gears and bearings for superior rigidity and maximum performance.
- Properly shimmed gears and bearings for consistent backlash.
- No paper or plastic shims. Metal shims used throughout.
- Tapered roller (not ball) bearings throughout.
- Aluminum end caps and pinion housings on most models for improved heat dissipation.
- High strength steel alloys – gears cut from 8620 steel, the carburized and hardened.
- Improved shaft seals – spring loaded double lip design. One lip seals in the oil, the other seals out dirt. All shafts are specially ground/burnished at the seal area for extended life.

Maintenance and Repair

- End caps and piston housings remove easily. (No need for a special access cover.) Only locking nuts or locking tab washers used internally. Threads are not staked.

Organized to Earn Your Confidence:

Every member of the VonRuden team works for you to provide a quality product, delivered on-time with the best possible service both before and after the sale. This company-wide commitment assures you:

- Very competitive prices.
- Improved delivery via flexible production schedules.
- Complete technical assistance from our global network of local representatives and our own engineering department.
- Direct support for your own customers when you request it.
- "Specials" will always be considered and usually built.

Over a Half-Century of Expertise

For over 50 years, VonRuden manufacturing has built its reputation around quality products, designed and built in modern, well-tooled facilities. Though our products and processes have certainly evolved over the decades our 21st Century commitment to superior products, competitive prices, and unexcelled service remains unchanged.

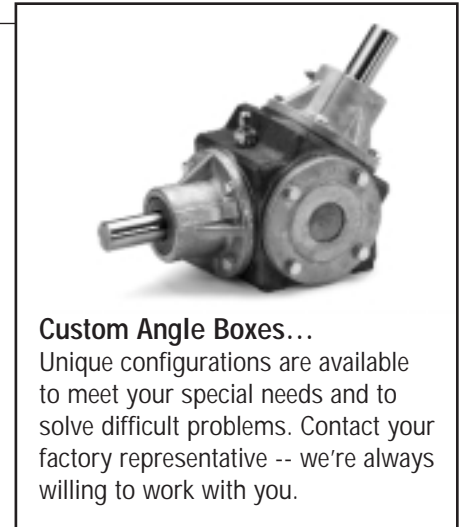

Bevel Gear Boxes PROBLEM-SOLVING EXPERIENCE

For Complete Specifications & Comprehensive Performance Data on All Bevel Gear Box Models
see www.vonruden.com.



07.08.03

Because we've been producing bevel gear boxes for over 50 years, Von Ruden brings substantial problem-solving experience to the table. Whether your goal is to blend, blow or bottle – you need to crank, cut or convey – or the task is to press, propel or raise, we welcome the opportunity to put our experience with all these industries to work for you.

Industrial Applications

Printing Presses
Plastic Extruders
Sewage Augers
Bonding Equipment
Metering Augers
Sewage Agitators
Newspaper Conveyors
Bottling Equipment
Material Handling
Web Finishing
Paper Conveying
Conveyors
Cardboard Box Equipment
Packaging
Antennas
Gate Valve Actuators
Business Form Presses
Feed Screw Drives
Sewage Conveyors
Collating Machinery
Mixing Equipment
Conveyor Drives
Film Processors
Pottle Packaging Equipment
Lifts/Hoists/Jacks
Food Processing
Robotics
Rubber Processing
Wrapping Machines
Solar Panels

Mobile & Other Applications

Commercial Mowers
Street Sweepers
Dual Steering
Bulkhead Door Openers
Scissors Lifts
Pump Drives
Misc. Conveyors
Sand Spreaders
Residential Mowers
Car Wash Curtains
Snow Blowers
Fan/Blower Drives
Mining Equipment
Cranes

Agricultural Applications

Augers/Elevators
Grain Wagons
Harvesters
Forage Harvesters/Blowers
Manure Spreaders
Fertilizer Spreaders
Grain Bin Augers
Grinders/Mixers
Tillers
Fans
Feed Mills/Blenders
Hay Balers
Tub Grinders
Grain Dryers
Rotary Mowers/Cutters
Power Rakes
Rock Pickers
Food Handling

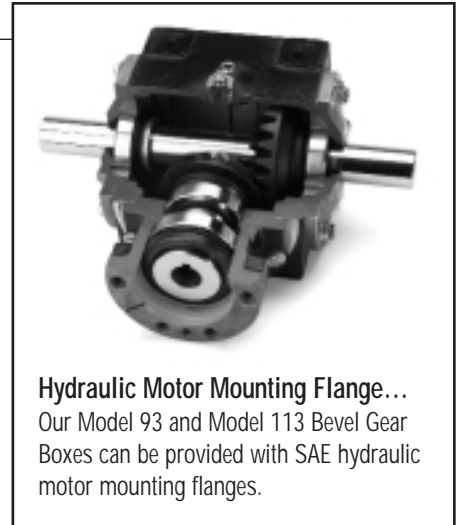

Hydraulic Motor Mounting Flange...
Our Model 93 and Model 113 Bevel Gear Boxes can be provided with SAE hydraulic motor mounting flanges.

Specials

Yes, Von Ruden will manufacture "specials" to satisfy unique customer requirements. Different shaft lengths, gear ratios and housing configurations can all be provided. These are examples of the hundreds of atypical configurations we've provided in the past.



Indeed, we might already have produced a custom design very similar to what you need. Please contact your factory representative for data on existing Von Ruden specials and a proposal for your application.